

2.0 Controller T2 / Schematic Diagrams

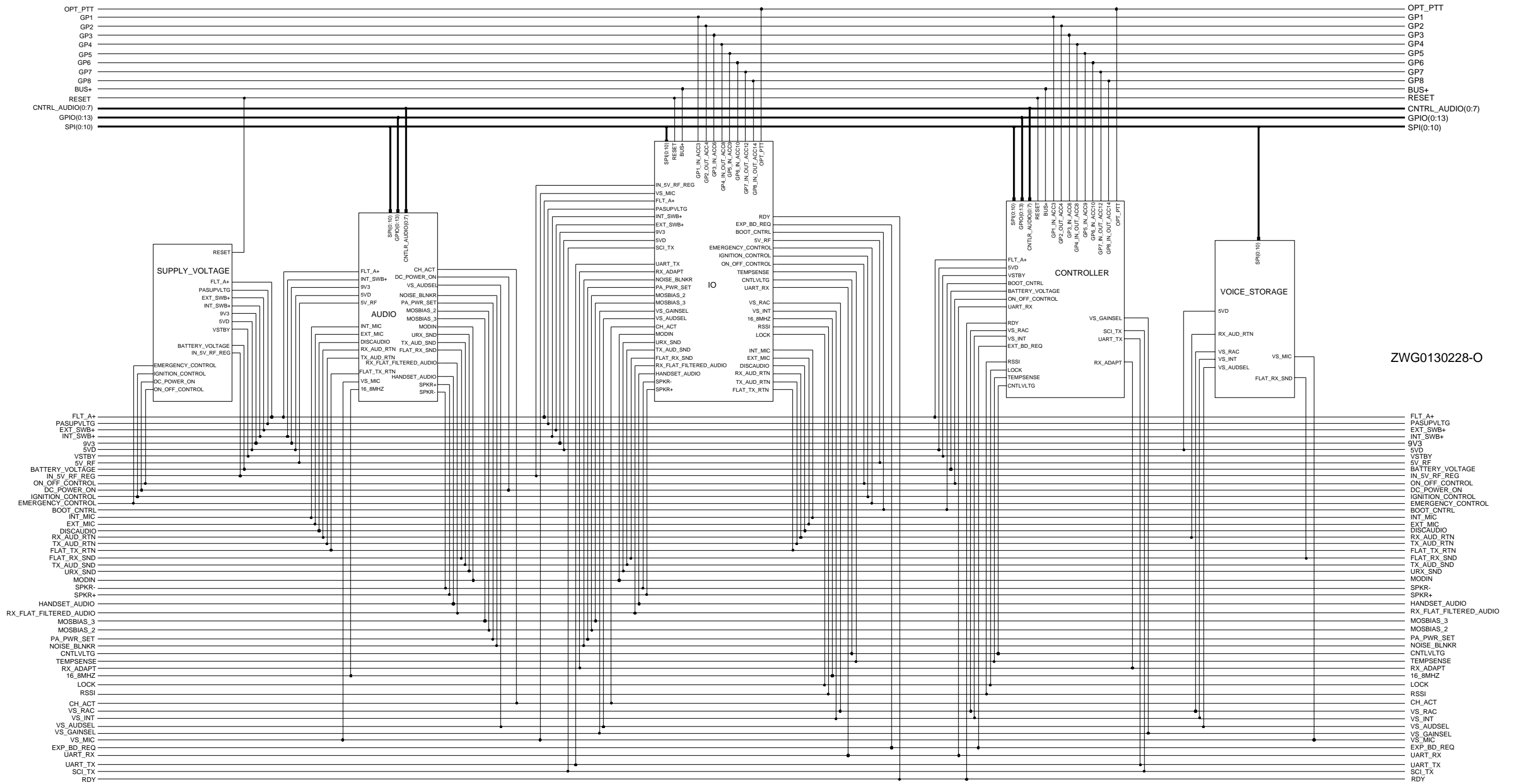

Controller T2 Schematic Diagram - Controller Overall

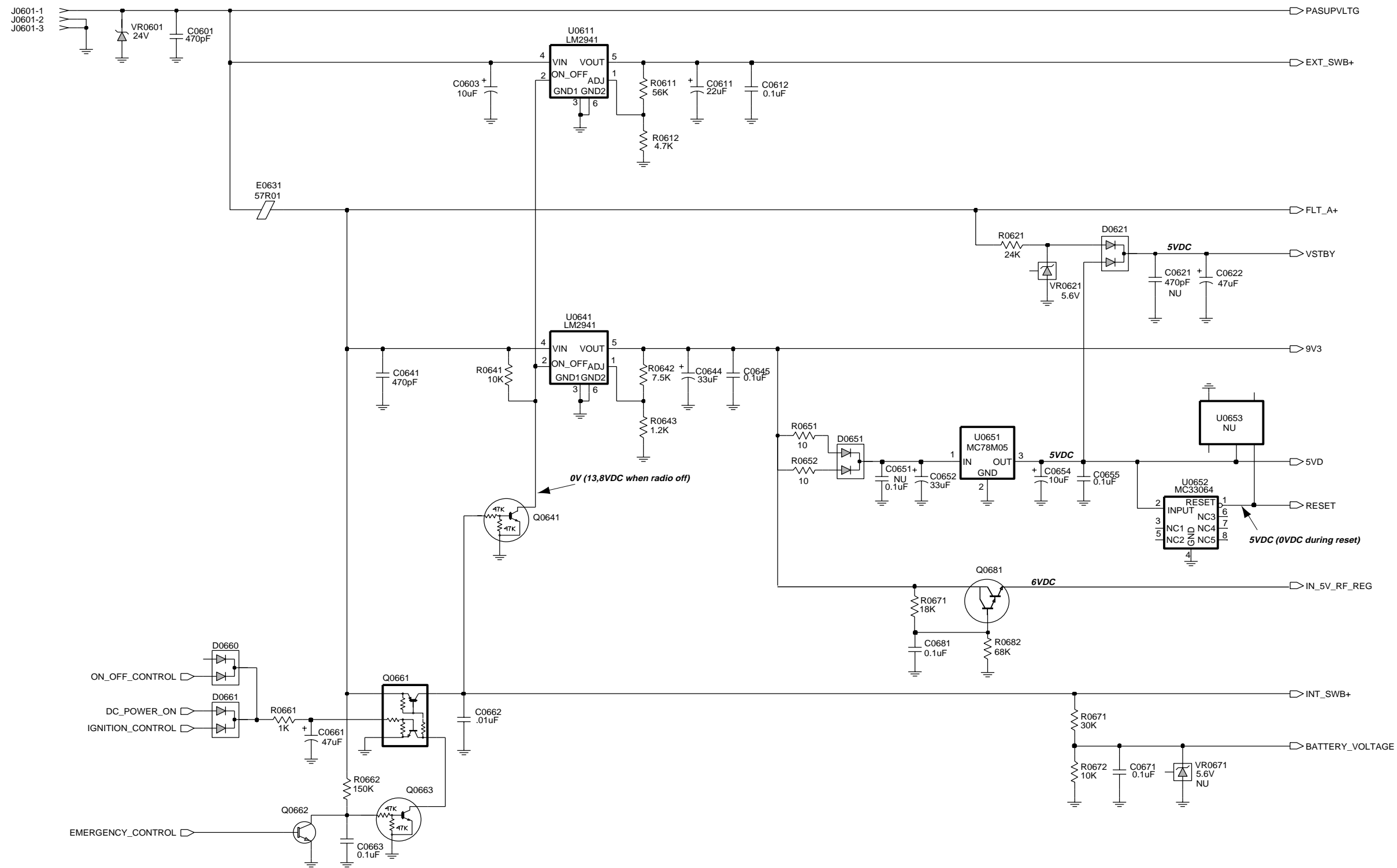

ZWG01300232-A

Controller T2 Schematic Diagram - Supply Voltage

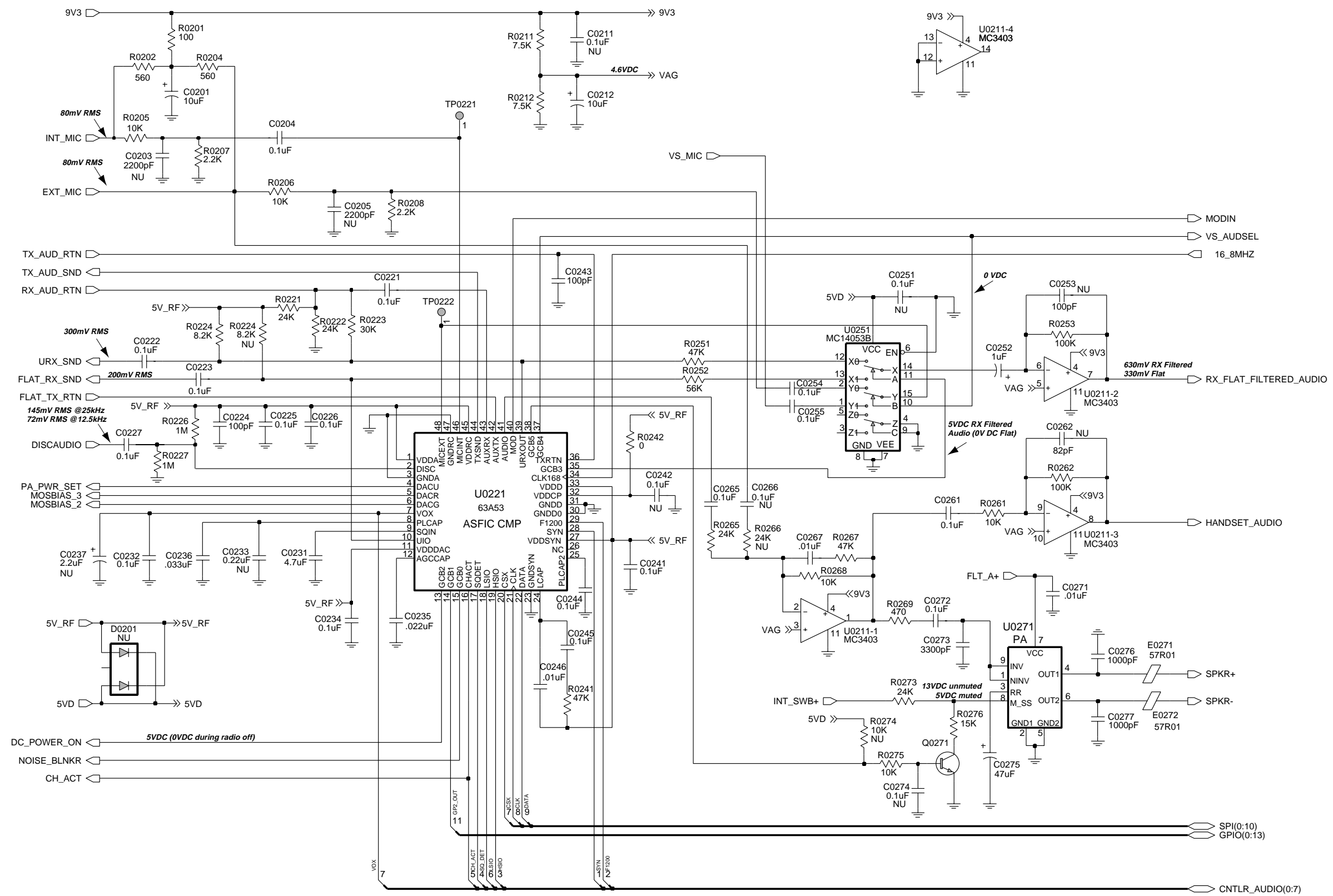

ZWG0130231-A

ControllerT2 Schematic Diagram - Audio

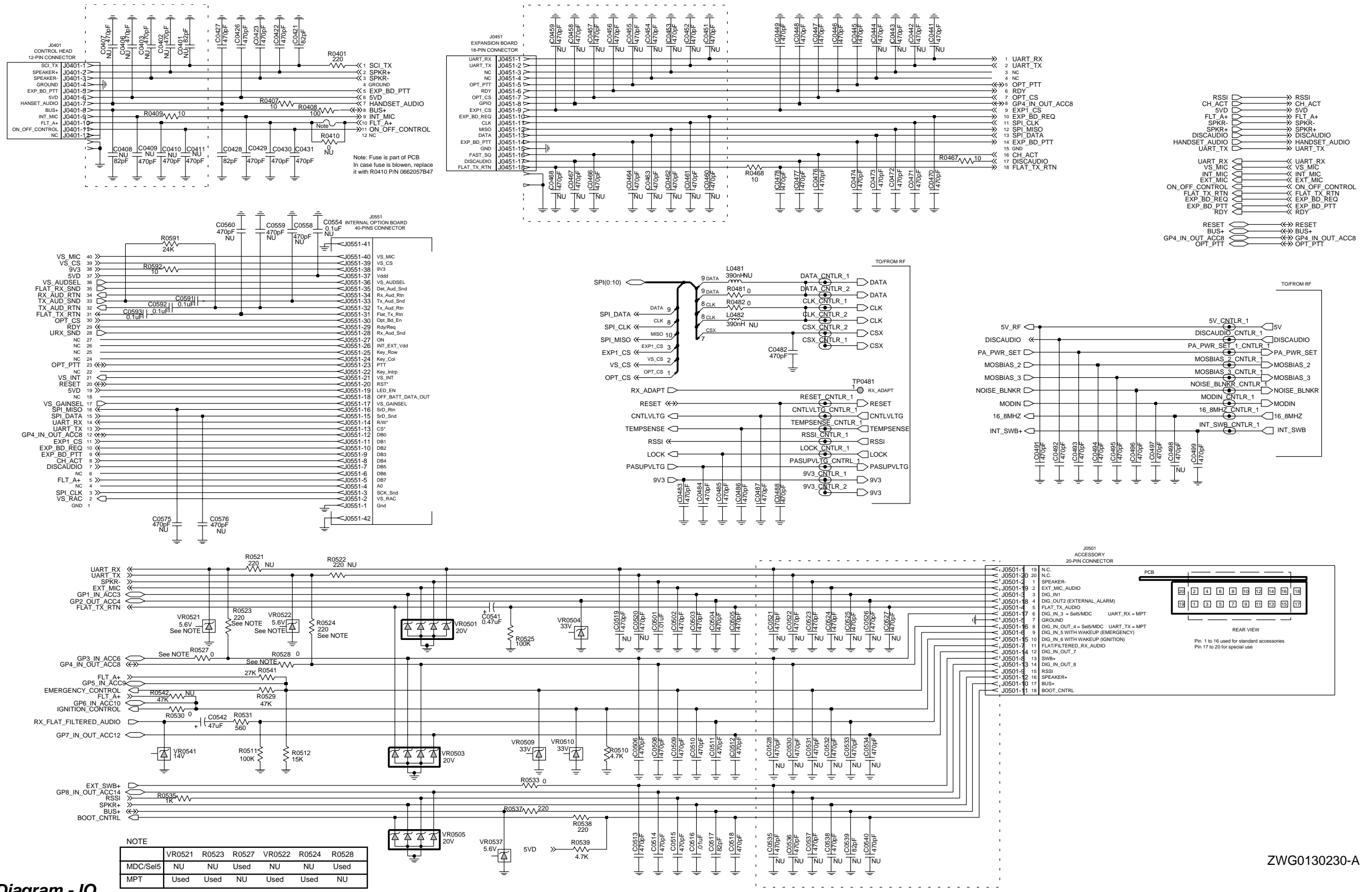

Controller T2
Schematic Diagram - IO

ZWG0130230-A

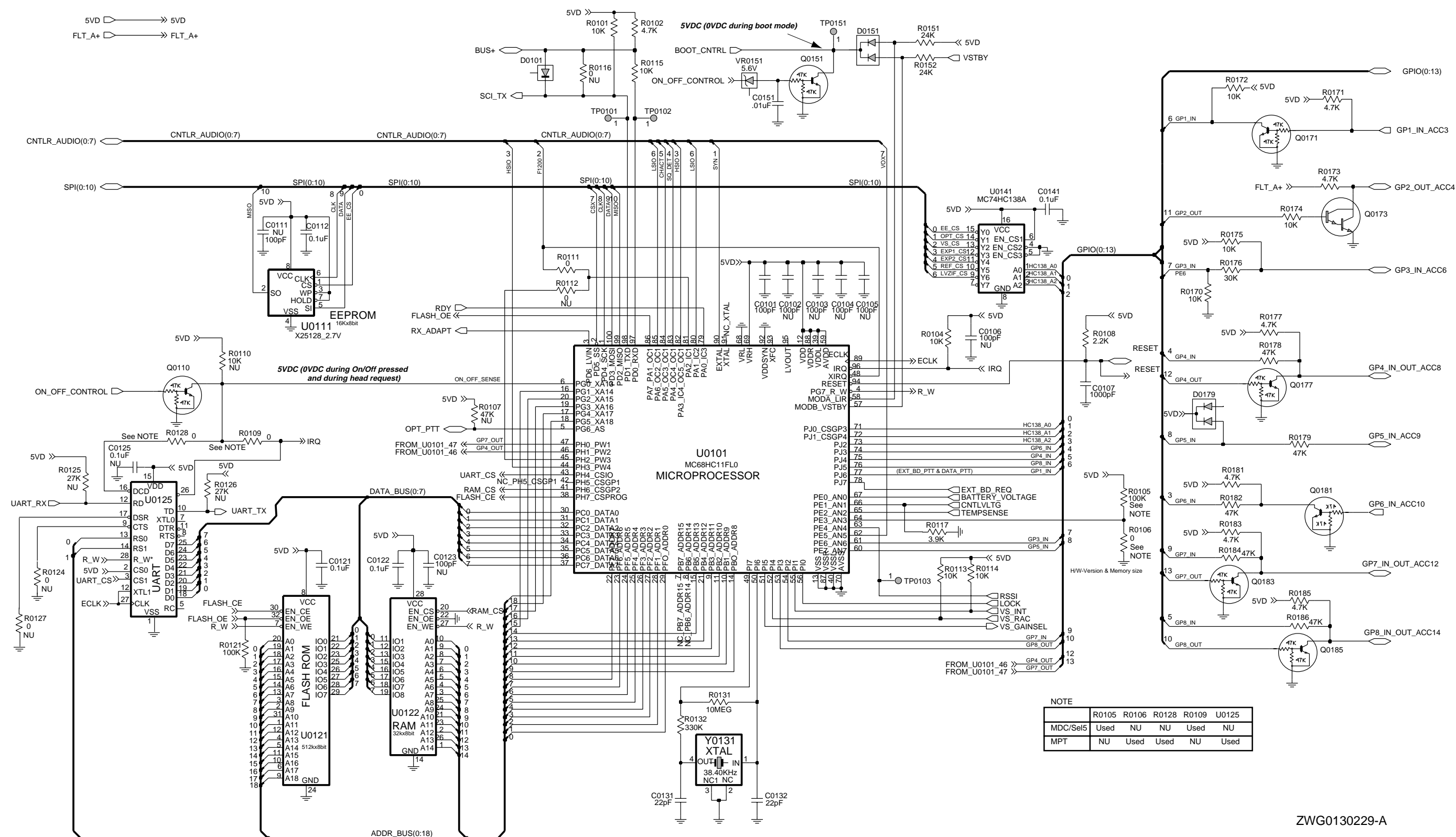

ZWG0130229-A

Controller T2 Schematic Diagram - Microprocessor

2.1 Controller T2 Parts List

Circuit Ref	Motorola Part No.	Description
C0101	2113740F51	100pF
C0107	2113741F25	1000pF
C0112	2113743E20	0.1uF
C0121	2113743E20	0.1uF
C0122	2113743E20	0.1uF
C0125	2113743E20	0.1uF
C0131	2113740F35	22pF
C0132	2113740F35	22pF
C0141	2113743E20	0.1uF
C0151	2113741F49	.01uF
C0201	2311049A57	10uF
C0204	2113743E20	0.1uF
C0212	2311049A57	10uF
C0221	2113743E20	0.1uF
C0222	2113743E20	0.1uF
C0223	2113743E20	0.1uF
C0224	2113740F51	100pF
C0225	2113743E20	0.1uF
C0226	2113743E20	0.1uF
C0227	2113743E20	0.1uF
C0231	2113743G24	2.2uF
C0232	2113743E20	0.1uF
C0234	2113743E20	0.1uF
C0235	2113743E07	.022uF
C0236	2113743E10	.033uF
C0241	2113743E20	0.1uF
C0243	2113740F51	100pF
C0244	2113743E20	0.1uF
C0245	2113743E20	0.1uF
C0246	2113741F49	.01uF
C0252	2311049A07	1uF
C0254	2113743E20	0.1uF
C0255	2113743E20	0.1uF
C0261	2113743E20	0.1uF
C0262	2113740F49	82pF
C0265	2113743E20	0.1uF
C0267	2113741F49	.01uF

Circuit Ref	Motorola Part No.	Description
C0271	2113741F49	.01uF
C0272	2113743E20	0.1uF
C0273	2113741F37	3300pF
C0275	2311049A99	47uF
C0276	2113741F25	1000pF
C0277	2113741F25	1000pF
C0421	2113743N48	82pF
C0422	2113741F17	470pF
C0423	2113741F17	470pF
C0426	2113743L09	470pF
C0427	2113743L09	470pF
C0428	2113743N48	82pF
C0429	2113743L09	470pF
C0430	2113741F17	470pF
C0431	2113741F17	470pF
C0441	2113743L09	470pF
C0442	2113743L09	470pF
C0445	2113743L09	470pF
C0446	2113743L09	470pF
C0447	2113743L09	470pF
C0448	2113743L09	470pF
C0449	2113743L09	470pF
C0470	2113743L09	470pF
C0471	2113743L09	470pF
C0472	2113743L09	470pF
C0473	2113743L09	470pF
C0474	2113743L09	470pF
C0476	2113743L09	470pF
C0477	2113743L09	470pF
C0478	2113743L09	470pF
C0482	2113743L09	470pF
C0483	2113743L09	470pF
C0484	2113741F17	470pF
C0485	2113743L09	470pF
C0486	2113743L09	470pF
C0487	2113743L09	470pF
C0488	2113743L09	470pF
C0490	2113743L09	470pF

Circuit Ref	Motorola Part No.	Description
C0491	2113743L09	470pF
C0492	2113743L09	470pF
C0493	2113743L09	470pF
C0494	2113743L09	470pF
C0495	2113743L09	470pF
C0496	2113743L09	470pF
C0497	2113743L09	470pF
C0499	2113743L09	470pF
C0501	2113741F49	.01uF
C0502	2113743L09	470pF
C0503	2113743L09	470pF
C0504	2113743L09	470pF
C0505	2113743L09	470pF
C0506	2113743L09	470pF
C0508	2113743L09	470pF
C0509	2113743L09	470pF
C0510	2113741F17	470pF
C0511	2113743L09	470pF
C0512	2113743L09	470pF
C0513	2113741F17	470pF
C0514	2113743L09	470pF
C0515	2113743L09	470pF
C0516	2113741F49	.01uF
C0517	2113743N48	82pF
C0518	2113743L09	470pF
C0541	2311049A05	0.47uF
C0542	2311049A99	47uF
C0591	2113743E20	0.1uF
C0592	2113743E20	0.1uF
C0593	2113743E20	0.1uF
C0601	2113741F17	470pF
C0603	2380090M24	10uF
C0611	2311049C06	22uF
C0612	2113743E20	0.1uF
C0622	2311049A99	47uF
C0641	2113741F17	470pF
C0644	2311049A97	33uF
C0645	2113743E20	0.1uF

Circuit Ref	Motorola Part No.	Description
C0652	2311049A97	33uF
C0654	2311049A57	10uF
C0655	2113743E20	0.1uF
C0661	2311049C05	47uF
C0662	2113741F49	.01uF
C0663	2113743E20	0.1uF
C0671	2113743E20	0.1uF
C0681	2113743E20	0.1uF
D0101	4880236E05	
D0151	4813833C02	
D0179	4813833C02	
D0621	4813833C02	
D0651	4813833C02	
D0660	4813833C02	
D0661	4813833C02	
E0271	2484657R01	57R01
E0272	2484657R01	57R01
E0631	2484657R01	
J0401	0902636Y02	
J0451	0902636Y01	
J0501	0986105B01	
J0551	0905505Y04	
J0601	0986165B01	
Q0110	4880048M01	
Q0151	4880048M01	
Q0171	4880048M01	
Q0173	4880052M01	
Q0177	4880048M01	
Q0181	4880048M01	
Q0183	4880048M01	
Q0185	4880048M01	
Q0271	4813824A10	
Q0641	4880048M01	
Q0661	4805921T02	
Q0662	4813824A10	
Q0663	4880048M01	
Q0681	4880052M01	
R0101	0662057A73	10K

Circuit Ref	Motorola Part No.	Description
R0102	0662057A65	4.7K
R0104	0662057A73	10K
R0105	0662057A97	100K
R0108	0662057A57	2.2K
R0111	0662057B47	0
R0113	0662057A73	10K
R0114	0662057A73	10K
R0115	0662057A73	10K
R0117	0662057A63	3.9K
R0121	0662057A97	100K
R0124	0662057B47	0
R0125	0662057A83	27K
R0126	0662057A83	27K
R0127	0662057B47	0
R0128	0662057B47	0
R0131	0662057B46	10MEG
R0132	0662057B10	330K
R0151	0662057A82	24K
R0152	0662057A82	24K
R0170	0662057A73	10K
R0171	0662057A65	4.7K
R0172	0662057A73	10K
R0173	0662057A65	4.7K
R0174	0662057A73	10K
R0175	0662057A73	10K
R0176	0662057A84	30K
R0177	0662057A65	4.7K
R0178	0662057A89	47K
R0179	0662057A89	47K
R0181	0662057A65	4.7K
R0182	0662057A89	47K
R0183	0662057A65	4.7K
R0184	0662057A89	47K
R0185	0662057A65	4.7K
R0186	0662057A89	47K
R0201	0662057A25	100
R0202	0662057A43	560
R0204	0662057A43	560

Circuit Ref	Motorola Part No.	Description
R0205	0662057A73	10K
R0206	0662057A73	10K
R0207	0662057A57	2.2K
R0208	0662057A57	2.2K
R0211	0660076E70	7.5K
R0212	0660076E70	7.5K
R0221	0662057A82	24K
R0222	0662057A82	24K
R0223	0662057A84	30K
R0224	0662057A71	8.2K
R0226	0662057B22	1MEG
R0227	0662057B22	1MEG
R0241	0662057A89	47K
R0242	0662057B47	0
R0251	0662057A89	47K
R0252	0662057A91	56K
R0253	0662057A97	100K
R0261	0662057A73	10K
R0262	0662057A97	100K
R0265	0662057A82	24K
R0267	0662057A89	47K
R0268	0662057A73	10K
R0269	0662057A41	470
R0273	0662057A82	24K
R0275	0662057A73	10K
R0276	0662057A77	15K
R0401	0662057A33	220
R0407	0662057M26	10
R0408	0662057A25	100
R0409	0662057M26	10
R0467	0662057M26	10
R0468	0662057M26	10
R0481	0662057B47	0
R0482	0662057B47	0
R0510	0662057A65	4.7K
R0511	0662057A97	100K
R0512	0662057A77	15K
R0523	0662057A33	220

Circuit Ref	Motorola Part No.	Description
R0524	0662057A33	220
R0525	0662057A97	100K
R0529	0662057A89	47K
R0530	0662057B47	0
R0531	0662057A43	560
R0533	0662057B47	0
R0535	0662057A49	1K
R0537	0662057A33	220
R0538	0662057A33	220
R0539	0662057A65	4.7K
R0541	0662057A83	27K
R0591	0662057A82	24K
R0592	0662057A01	10
R0611	0662057A91	56K
R0612	0662057A65	4.7K
R0621	0662057A82	24K
R0641	0662057A73	10K
R0642	0660076E70	7.5K
R0643	0660076E51	1.2K
R0651	0662057A01	10
R0652	0662057A01	10
R0661	0662057A49	1K
R0662	0662057B02	150K
R0671	0662057A84	30K
R0672	0662057A73	10K
R0681	0662057A79	18K
R0682	0662057A93	68K
U0101	5102226J56	MC68HC11FL0
* U0111	5102463J64	X25128-2.7
* U0121	5186137B01	AT49F040
U0122	5185963A21	63A21
U0125	5105625U34	CDP65C51A
U0141	5113805A30	MC74HC138A
U0211	5183222M49	MC3403
U0221	5185963A53	63A53
U0251	5113806A20	MC14053B
U0271	5109699X01	TDA1519C
U0611	5183308X01	LM2941

Circuit Ref	Motorola Part No.	Description
U0641	5183308X01	LM2941
U0651	5113816A07	MC78M05
U0652	5113815A02	MC33064
U0653	4805921T02	NU
VR0151	4813830A15	5.6V
VR0501	4805656W09	20V
VR0503	4805656W09	20V
VR0504	4813830A40	33V
VR0505	4805656W09	20V
VR0509	4813830A40	33V
VR0510	4813830A40	33V
VR0521	4813830A15	5.6V
VR0522	4813830A15	5.6V
VR0537	4813830A15	5.6V
VR0541	4813830A27	14V
VR0601	4813832C77	24V
VR0621	4813830A15	5.6V
Y0131	4880113R19	XTAL

* Motorola Depot Servicing only
 Reference designators with an asterisk indicate components which are not fieldreplaceable because they need to be calibrated with specialized factory equipment after installation. Radios in which these parts have been replaced in the field will be off frequency at temperature extremes.

3.0 Controller T5 / Schematic Diagrams

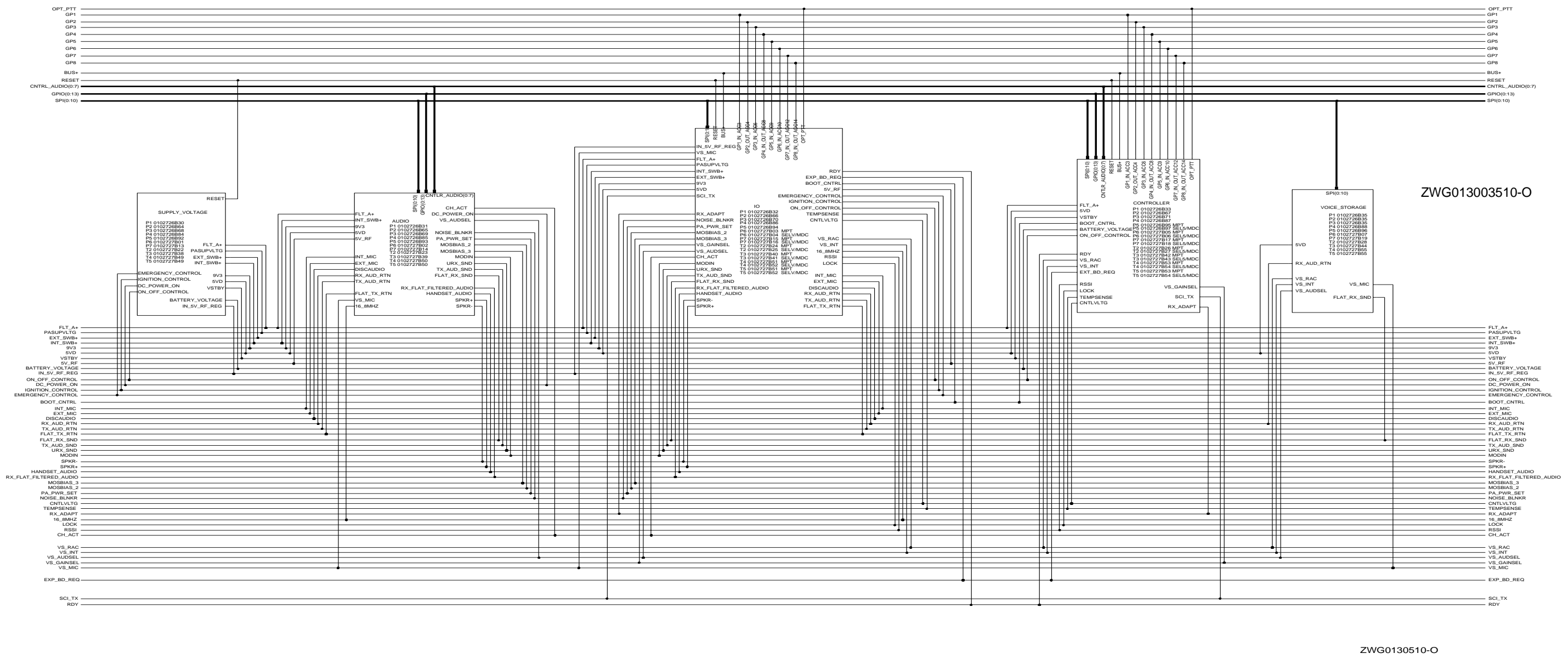

Controller T5 Schematic Diagram - Controller Overall

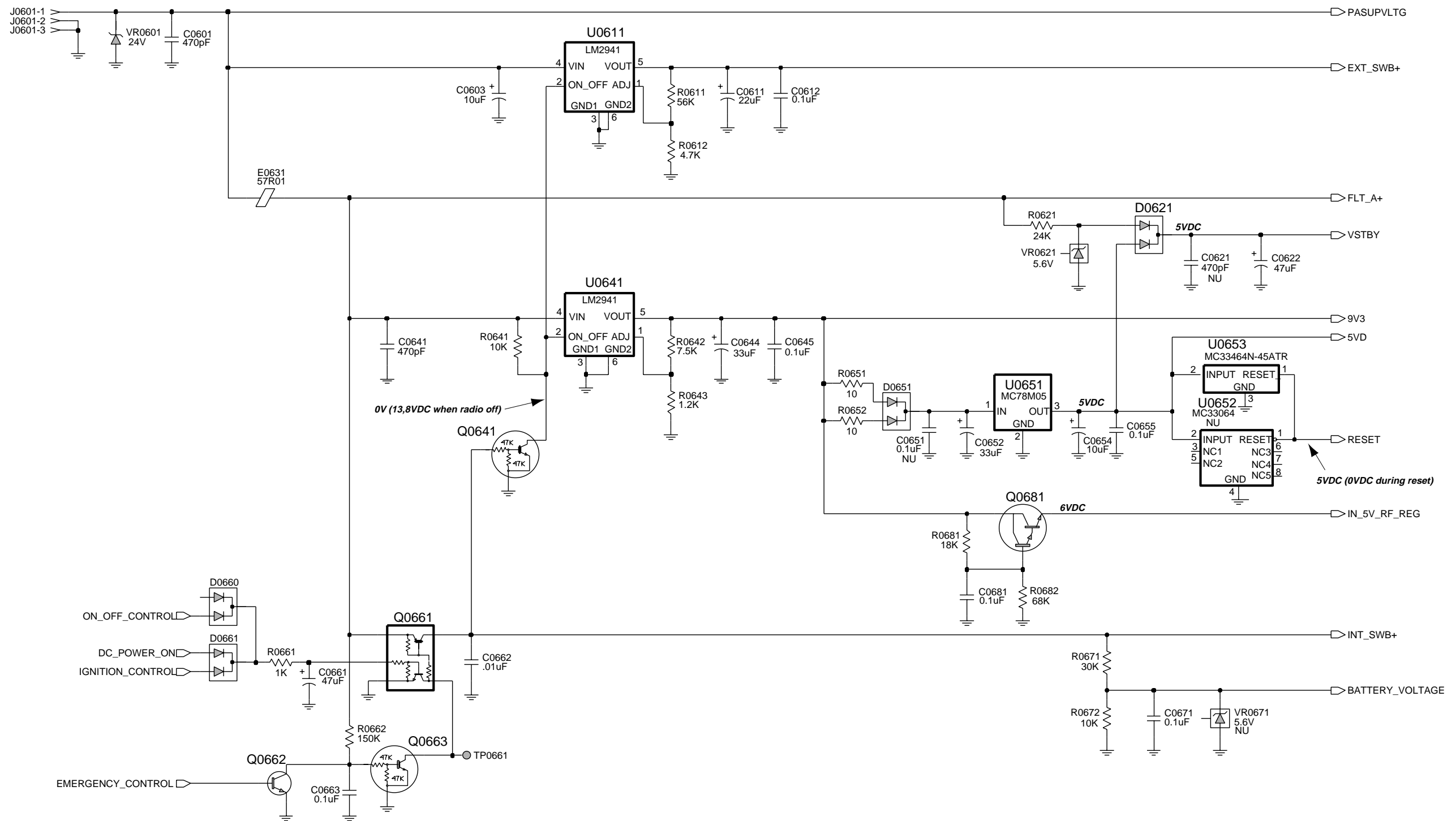

ZWG013030506-O

Controller T5 Schematic Diagram - Supply Voltage

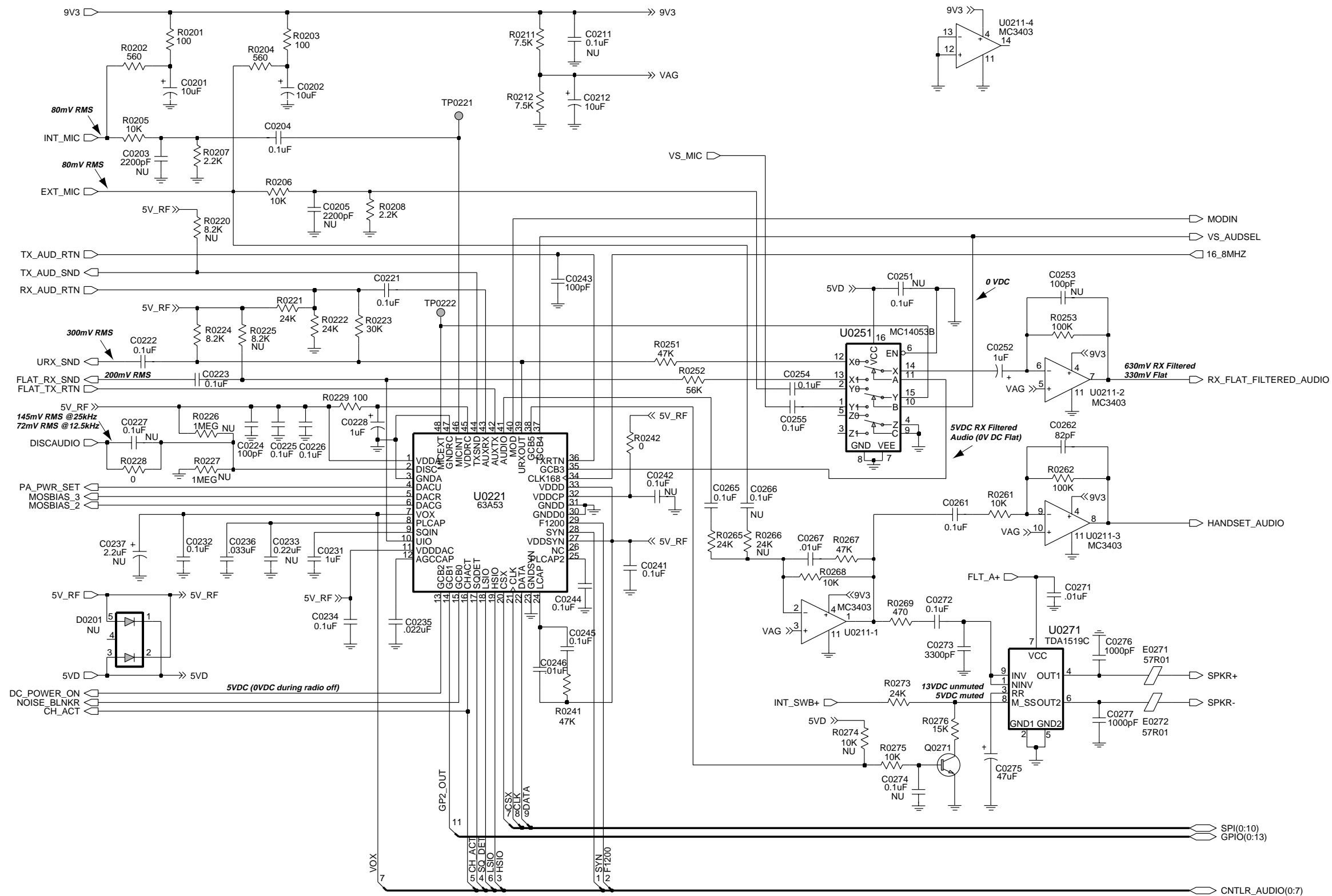

ZWG0130507-O

**Controller T5
Schematic Diagram -
Audio**

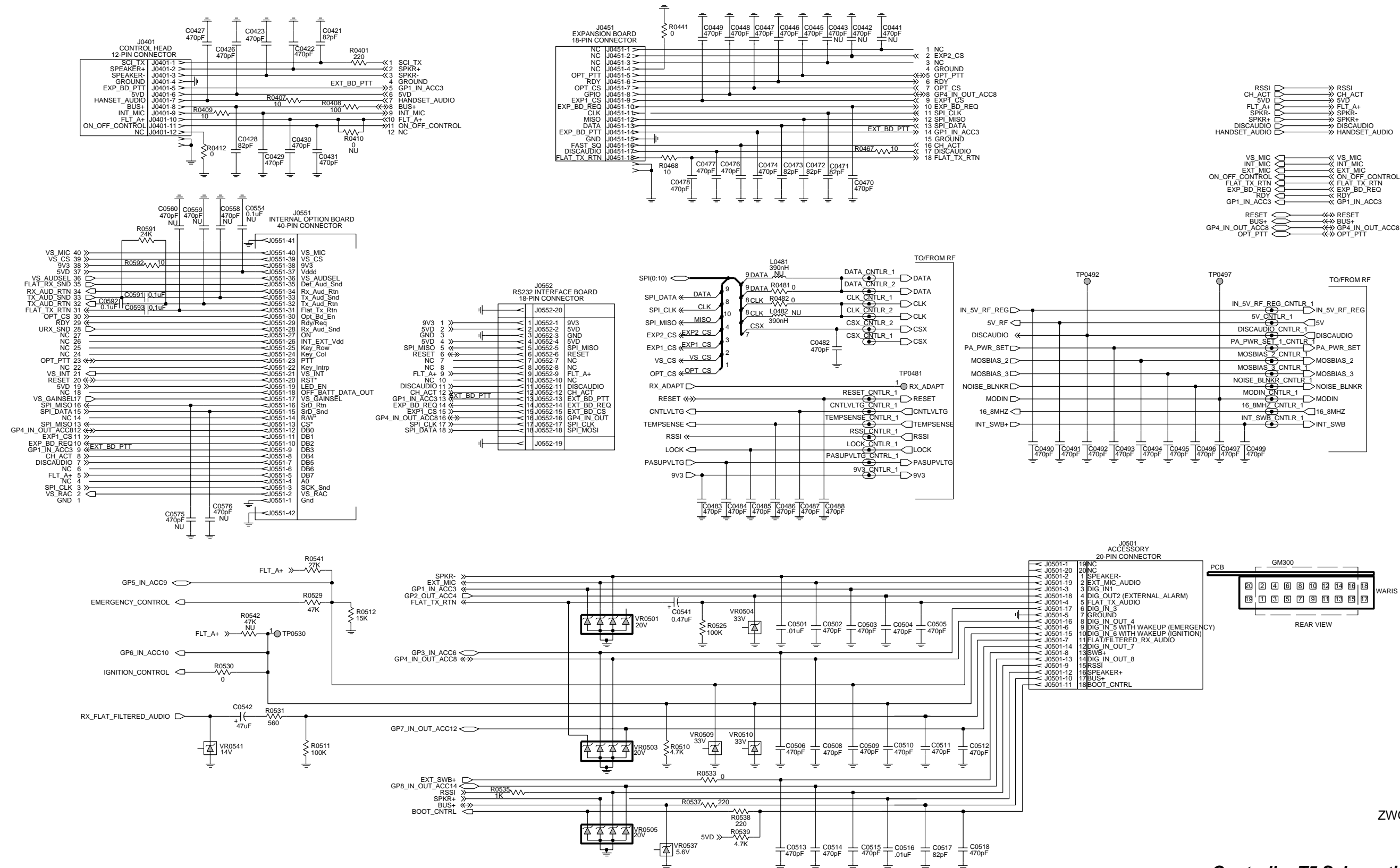

Controller T5 Schematic Diagram - I/O

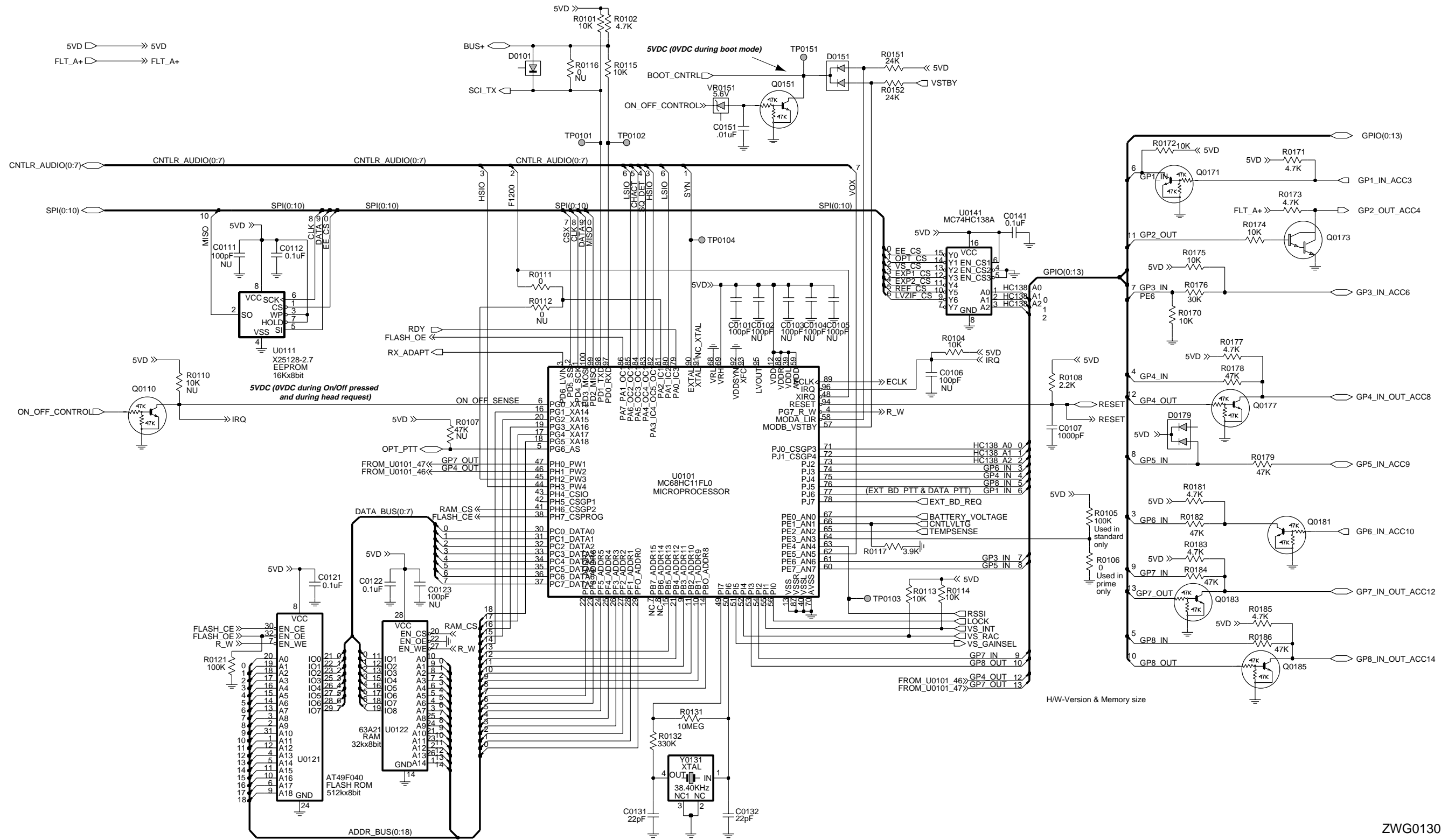

H/W-Version & Memory size

ZWG0130509-A

Controller T5 Schematic Diagram - Microprocessor

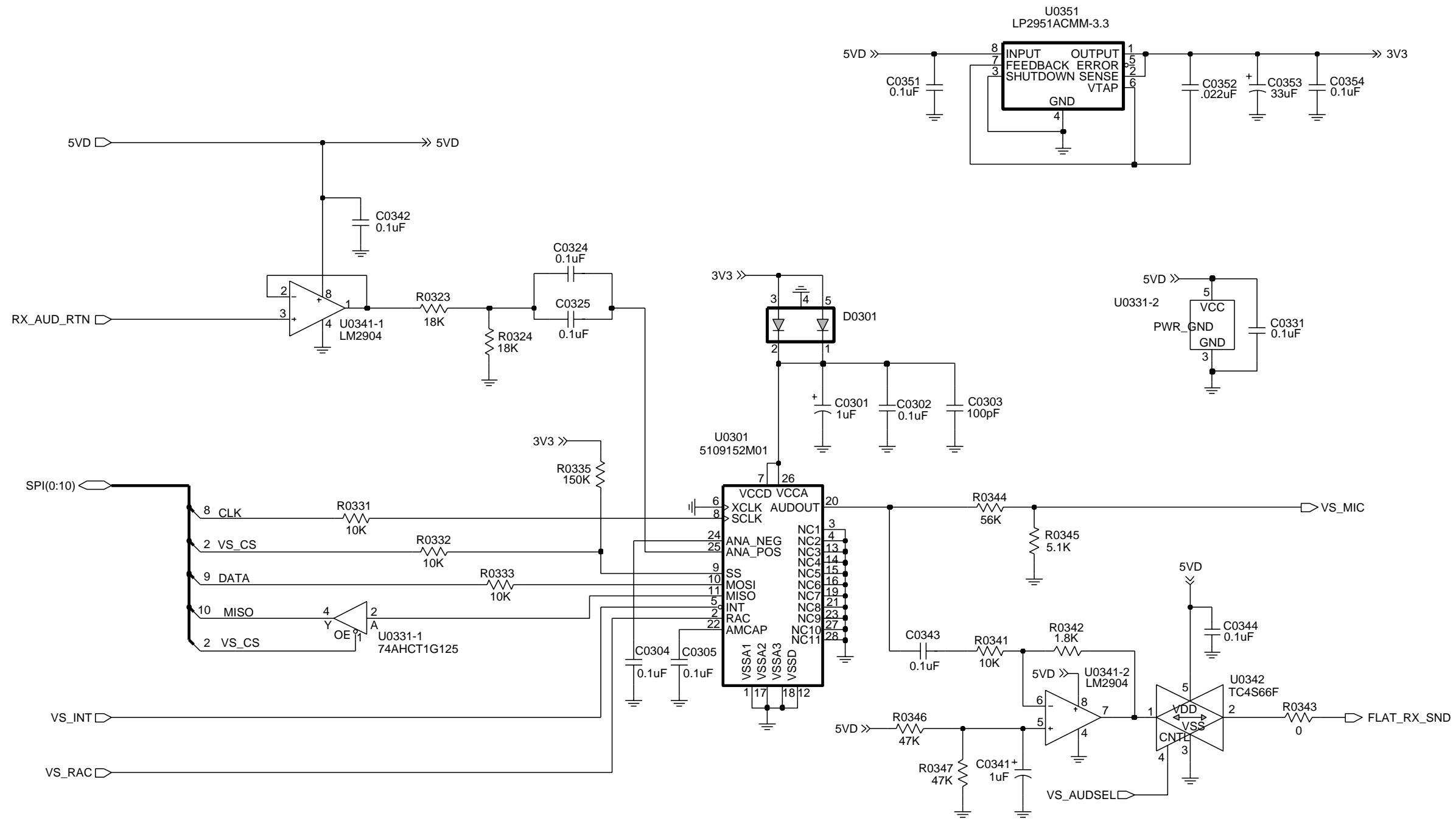

ZWG0130505-O

Controller T5 Schematic Diagram - Voice Storage

3.1 Controller T5 Parts List

Circuit Ref	Motorola Part No	Description
C0101	2113740F51	100pF 5% 50V
C0107	2113741F25	1nF 50V
C0112	2113743E20	100nF 16V
C0121	2113743E20	100nF 16V
C0122	2113743E20	100nF 16V
C0131	2113740F35	22pF 5% 50V
C0132	2113740F35	22pF 5% 50V
C0141	2113743E20	100nF 16V
C0151	2113741F49	10nF 50V
C0201	2311049A57	TANT CP 10uF 10% 16V
C0202	2311049A57	TANT CP 10uF 10% 16V
C0204	2113743E20	100nF 16V
C0212	2311049A57	TANT CP 10uF 10% 16V
C0221	2113743E20	100nF 16V
C0222	2113743E20	100nF 16V
C0223	2113743E20	100nF 16V
C0224	2113740F51	100pF 5% 50V NPO
C0225	2113743E20	100nF 16V
C0226	2113743E20	100nF 16V
C0228	2311049A07	TANT CP 1uF 10% 16V
C0231	2113743B29	1 UF 10% 16V
C0232	2113743E20	100nF 16V
C0234	2113743E20	100nF 16V
C0235	2113743E07	22nF 16V
C0236	2113743E10	.033UF 10%
C0241	2113743E20	100nF 16V
C0243	2113740F51	100pF 5% 50V
C0244	2113743E20	100nF 16V
C0245	2113743E20	100nF 16V
C0246	2113741F49	10nF 50V
C0252	2311049A07	TANT CP 1uF 10%
C0254	2113743E20	100nF 16V
C0255	2113743E20	100nF 16V
C0261	2113743E20	100nF 16V
C0262	2113740F49	82pF 5% 50V
C0265	2113743E20	100nF 16V
C0267	2113741F49	10nF 50V
C0271	2113741F49	10nF 50V
C0272	2113743E20	100nF 16V
C0273	2113741F37	3.3nF 50V
C0275	2311049A99	TANT CP 47uF 20% 10V
C0276	2113741F25	1nF 50V
C0277	2113741F25	1nF 50V
C0301 Used in	2311049A07 GM1280 only	1uF 10% 16V

Circuit Ref	Motorola Part No	Description
C0302 Used in	2113743E20 GM1280 only	100nF 16V
C0303 Used in	2113740F51 GM1280 only	100pF 5% 50V
C0304 Used in	2113743E20 GM1280 only	100nF 16V
C0305 Used in	2113743E20 GM1280 only	100nF 16V
C0324 Used in	2113743E20 GM1280 only	100nF 16V
C0331 Used in	2113743E20 GM1280 only	100nF 16V
C0341 Used in	2311049A07 GM1280 only	TANT CP 1uF 10% 16V
C0342 Used in	2113743E20 GM1280 only	100nF 16V
C0343 Used in	2113743E20 GM1280 only	100nF 16V
C0344 Used in	2113743E20 GM1280 only	100nF 16V
C0351 Used in	2113743E20 GM1280 only	100nF 16V
C0352 Used in	2113743E07 GM1280 only	22nF 16V
C0353 Used in	2311049A97 GM1280 only	TANT CHIP 33 UF 16
C0354 Used in	2113743E20 GM1280 only	100nF 16V
C0421	2113743N48	82.0 PF 5%
C0422	2113741F17	470pF 50V
C0423	2113741F17	470pF 50V
C0426	2113743L09	470 PF 10%
C0427	2113743L09	470 PF 10%
C0428	2113743N48	82.0 PF 5%
C0429	2113743L09	470 PF 10%
C0430	2113741F17	470pF 50V
C0431	2113741F17	470pF 50V
C0445	2113743L09	470 PF 10%
C0446	2113743L09	470 PF 10%
C0447	2113743L09	470 PF 10%
C0448	2113743L09	470 PF 10%
C0449	2113743L09	470 PF 10%
C0470	2113743L09	470 PF 10%
C0471	2113743N48	82.0 PF 5%
C0472	2113743N48	82.0 PF 5%
C0473	2113743N48	82.0 PF 5%
C0474	2113743L09	470 PF 10%
C0476	2113743L09	470 PF 10%
C0477	2113743L09	470 PF 10%

Circuit Ref	Motorola Part No	Description
C0478	2113743L09	470 PF 10%
C0482	2113743L09	470 PF 10%
C0483	2113743L09	470 PF 10%
C0484	2113741F17	470 pF 50V
C0485	2113743L09	470 PF 10%
C0486	2113743L09	470 PF 10%
C0487	2113743L09	470 PF 10%
C0488	2113743L09	470 PF 10%
C0490	2113743L09	470 PF 10%
C0491	2113743L09	470 PF 10%
C0492	2113743L09	470 PF 10%
C0493	2113743L09	470 PF 10%
C0494	2113743L09	470 PF 10%
C0495	2113743L09	470 PF 10%
C0496	2113743L09	470 PF 10%
C0497	2113743L09	470 PF 10%
C0499	2113743L09	470 PF 10%
C0501	2113741F49	10nF 50V
C0502	2113743L09	470 PF 10%
C0503	2113743L09	470 PF 10%
C0504	2113743L09	470 PF 10%
C0505	2113743L09	470 PF 10%
C0506	2113743L09	470 PF 10%
C0508	2113743L09	470 PF 10%
C0509	2113743L09	470 PF 10%
C0510	2113741F17	470 pF 50V
C0511	2113743L09	470 PF 10%
C0512	2113743L09	470 PF 10%
C0513	2113741F17	470 pF 50V
C0514	2113743L09	470 PF 10%
C0515	2113743L09	470 PF 10%
C0516	2113741F49	10nF 50V
C0517	2113743N48	82.0 PF 5%
C0518	2113743L09	470 PF 10%
C0541	2311049A05	TANT CP 470nF 10% 25V
C0542	2311049A99	TANT CP 47uF 20% 10V
C0591	2113743E20	100nF 16V
C0592	2113743E20	100nF 16V
C0593	2113741B69	100nF 50V
C0601	2113741F17	470pF 50V
C0603	2380090M24	LYT 10uF 50V 20%
C0611	2311049C06	TANT CP 22uF 20% 35V
C0612	2113743E20	100nF 16V
C0622	2311049A99	TANT CP 47uF 20% 10V
C0641	2113741F17	470pF 50V
C0644	2311049A97	TANT CHIP 33 UF 16
C0645	2113743E20	100nF 16V

Circuit Ref	Motorola Part No	Description
C0652	2311049A97	TANT CHIP 33 UF 16
C0654	2311049A57	TANT CP 10uF 10% 16V
C0655	2113743E20	100nF 16V
C0661	2311049C05	TANT CP 47uF 10% 16V
C0662	2113741F49	10nF 50V
C0663	2113743E20	100nF 16V
C0671	2113743E20	100nF 16V
C0681	2113743E20	100nF 16V
D0101	4880236E05	CHIP SCHOTTKY
D0151	4813833C02	DUAL SOT MMBD6100
D0179	4813833C02	DUAL SOT MMBD6100
D0301 Used in	4802245J47 GM1280 only	SCHOTTKY BARRIER (RB471E)
D0621	4813833C02	DUAL SOT MMBD6100
D0651	4813833C02	DUAL SOT MMBD6100
D0660	4813833C02	DUAL SOT MMBD6100
D0661	4813833C02	DUAL SOT MMBD6100
E0271	2484657R01	Ferrite Bead
E0272	2484657R01	Ferrite Bead
E0631	2484657R01	Ferrite Bead
J0401	0902636Y02	CONN FLEX 12 PIN
J0451	0902636Y01	CONN FLEX SIDE ENTRY
J0501	0986105B01	CONN SMD 20 PIN
J0551	0905505Y04	CONN ZIF HORIZONTAL
J0552	0905505Y03	CONN ZIF 18PIN
J0601	0986165B01	DC PWR CONN
Q0110	4880048M01	NPN DIG 47k/47k
Q0151	4880048M01	NPN DIG 47k/47k
Q0171	4880048M01	NPN DIG 47k/47k
Q0173	4880052M01	NPN DRLNGTN MXTA
Q0177	4880048M01	NPN DIG 47k/47k
Q0181	4880048M01	NPN DIG 47k/47k
Q0183	4880048M01	NPN DIG 47k/47k
Q0185	4880048M01	NPN DIG 47k/47k
Q0271	4813824A10	NPN 40V .2A
Q0641	4880048M01	NPN DIG 47k/47k
Q0661	4805921T02	DUAL ROHM FMC2 RH
Q0662	4813824A10	NPN 40V .2A B=50-150
Q0663	4880048M01	NPN DIG 47k/47k
Q0681	4880052M01	NPN DRLNGTN MXTA
R0101	0662057A73	10k 1/16W 5%
R0102	0662057A65	4k7 1/16W 5%
R0104	0662057A73	10k 1/16W 5%
R0105	0662057A97	100k 1/16W
Used in	GM140/160	GM340/360/640/660 only
R0106	0662057B47	0 1/16W
Used in	GM380	GM1280 only
R0108	0662057A57	2k2 1/16W 5%

Circuit Ref	Motorola Part No	Description
R0111	0662057B47	0 1/16W
R0113	0662057A73	10k 1/16W 5%
R0114	0662057A73	10k 1/16W 5%
R0115	0662057A73	10k 1/16W 5%
R0117	0662057A63	3k9 1/16W 5%
R0121	0662057A97	100k 1/16W
R0131	0662057B46	10.0 MEG OHMS 5%
R0132	0662057B10	330k 1/16W 5%
R0151	0662057A82	24K 1/16W 5%
R0152	0662057A82	24K 1/16W 5%
R0170	0662057A73	10k 1/16W 5%
R0171	0662057A65	4k7 1/16W 5%
R0172	0662057A73	10k 1/16W 5%
R0173	0662057A65	4k7 1/16W 5%
R0174	0662057A73	10k 1/16W 5%
R0175	0662057A73	10k 1/16W 5%
R0176	0662057A84	30k 1/16W 5%
R0177	0662057A65	4k7 1/16W 5%
R0178	0662057A89	47k 1/16W 5%
R0179	0662057A89	47k 1/16W 5%
R0181	0662057A65	4k7 1/16W 5%
R0182	0662057A89	47k 1/16W 5%
R0183	0662057A65	4k7 1/16W 5%
R0184	0662057A89	47k 1/16W 5%
R0185	0662057A65	4k7 1/16W 5%
R0186	0662057A89	47k 1/16W 5%
R0201	0662057A25	100 1/16W 5%
R0202	0662057A43	560 1/16W 5%
R0203	0662057A25	100 1/16W 5%
R0204	0662057A43	560 1/16W 5%
R0205	0662057A73	10k 1/16W 5%
R0206	0662057A73	10k 1/16W 5%
R0207	0662057A57	2k2 1/16W 5%
R0208	0662057A57	2k2 1/16W 5%
R0211	0660076E70	FILM 7500
R0212	0660076E70	FILM 7500
R0221	0662057A82	24K 1/16W 5%
R0222	0662057A82	24K 1/16W 5%
R0223	0662057A84	30k 1/16W 5%
R0224	0662057A71	8k2 1/16W 5%
R0228	0662057B47	0 1/16W
R0229	0662057A25	100 1/16W 5%
R0241	0662057A89	47k 1/16W 5%
R0242	0662057B47	0 1/16W
R0251	0662057A89	47k 1/16W 5%
R0252	0662057A91	56K 1/16W 5%
R0253	0662057A97	100k 1/16W

Circuit Ref	Motorola Part No	Description
R0261	0662057A73	10k 1/16W 5%
R0262	0662057A97	100k 1/16W
R0265	0662057A82	24K 1/16W 5%
R0267	0662057A89	47k 1/16W 5%
R0268	0662057A73	10k 1/16W 5%
R0269	0662057A41	470 1/16W 5%
R0273	0662057A82	24K 1/16W 5%
R0275	0662057A73	10k 1/16W 5%
R0276	0662057A77	15k 1/16W 5%
R0323	0662057A79	18k 1/16W 5%
Used in	GM1280 only	
R0324	0662057A79	18k 1/16W 5%
Used in	GM1280 only	
R0331	0662057A73	10k 1/16W 5%
Used in	GM1280 only	
R0332	0662057A73	10k 1/16W 5%
Used in	GM1280 only	
R0333	0662057A73	10k 1/16W 5%
Used in	GM1280 only	
R0335	0662057B02	150k 1/16W
Used in	GM1280 only	
R0341	0662057A73	10k 1/16W 5%
Used in	GM1280 only	
R0342	0662057A55	1k8 1/16W 5%
Used in	GM1280 only	
R0343	0662057B47	0 1/16W
Used in	GM1280 only	
R0344	0662057A91	56K 1/16W 5%
Used in	GM1280 only	
R0345	0662057A66	5k1 1/16W 5%
Used in	GM1280 only	
R0346	0662057A89	47k 1/16W 5%
Used in	GM1280 only	
R0347	0662057A89	47k 1/16W 5%
Used in	GM1280 only	
R0401	0662057A33	220 1/16W 5%
R0407	0662057M26	10 5%
R0408	0662057A25	100 1/16W 5%
R0409	0662057M26	10 5%
R0412	0662057B47	0 1/16W
R0441	0662057B47	0 1/16W
R0467	0662057M26	10 5%
R0468	0662057M26	10 5%
R0481	0662057B47	0 1/16W
R0482	0662057B47	0 1/16W
R0510	0662057A65	4k7 1/16W 5%
R0511	0662057A97	100k 1/16W
R0512	0662057A77	15k 1/16W 5%
R0525	0662057A97	100k 1/16W

Circuit Ref	Motorola Part No	Description
R0529	0662057A89	47k 1/16W 5%
R0530	0662057B47	0 1/16W
R0531	0662057A43	560 1/16W 5%
R0533	0662057B47	0 1/16W
R0535	0662057A49	1k 1/16W
R0537	0662057A33	220 1/16W 5%
R0538	0662057A33	220 1/16W 5%
R0539	0662057A65	4k7 1/16W 5%
R0541	0662057A83	27k 1/16W 5%
R0591	0662057A82	24K 1/16W 5%
R0592	0662057A01	10 1/16W 5%
R0611	0662057A91	56K 1/16W 5%
R0612	0662057A65	4k7 1/16W 5%
R0621	0662057A82	24K 1/16W 5%
R0641	0662057A73	10k 1/16W 5%
R0642	0660076E70	FILM 7500 1 1
R0643	0660076E51	FILM 1200 1 1
R0651	0662057A01	10 1/16W 5%
R0652	0662057A01	10 1/16W 5%
R0661	0662057A49	1k 1/16W 5%
R0662	0662057B02	150k 1/16W
R0671	0662057A84	30k 1/16W 5%
R0672	0662057A73	10k 1/16W 5%
R0681	0662057A79	18k 1/16W 5%
R0682	0662057A93	68k 1/16W 5%
U0101	5102226J56	MICRO PROCESSOR MC68HC1
* U0111	5102463J64	EEPROM X25128-2.7 SO8
* U0121	5186137B01	IC 512KX8 FLASH ROM (AT49BV020)
U0122	5185963A21	IC 32K x 8 SRAM
U0141	5113805A30	IC 10F8 DCDR/REMUX 74HC138
U0211	5183222M49	IC QUAD OPAMP _ 3403
U0221	5185963A53	ASFICCMP 0.5MM TQFP
U0251	5113806A20	MUX/DEMUX,TRIPLE 2-
U0271	5109699X01	AUDIO PA TDA1519C
U0301	5109152M01	EEPROM ANALOG
Used in	GM1280 only	ISD33120EI
U0331	5186204B01	BUFFER/DRIVER
Used in	GM1280 only	74AHCT1G125
U0341	5180932W01	LINEAR IC OP AMP
Used in	GM1280 only	
U0342	5105750U28	SNGL ANALOG SWITCH
Used in	GM1280 only	
U0351	5102463J40	REGULATOR, 3.3V
Used in	GM1280 only	
U0611	5183308X01	ADJ VLTG REG LM2941 TO263

Circuit Ref	Motorola Part No	Description
U0641	5183308X01	ADJ VLTG REG LM2941 TO263
U0651	5113816A07	REG 5V POS 500MA MC78M05
U0653	5186205B01	MC33464N-45ATR SOT23-5-RB
VR0151	4813830A15	5.6V 5% 225mW
VR0501	4805656W09	ZENER QUAD MMQA20VT1
VR0503	4805656W09	ZENER QUAD MMQA20VT1
VR0504	4813830A40	SOC23 AUTO SDN
VR0505	4805656W09	ZENER QUAD MMQA20VT1
VR0509	4813830A40	SOC23 AUTO SDN
VR0510	4813830A40	SOC23 AUTO SDN
VR0537	4813830A15	5.6V 5% 225mW
VR0541	4813830A27	14V 5% 225MW
VR0601	4813832C77	TRANS SUP. 24V HIGPWR
VR0621	4813830A15	DIODE 5.6V 5% 225mW
Y0131	4880113R19	CRYSTAL 38.4KHZ

* Motorola Depot Servicing only
 Reference designators with an asterisk indicate components which are not fieldreplaceable because they need to be calibrated with specialized factory equipment after installation. Radios in which these parts have been replaced in the field will be off frequency at temperature extremes.

4.0 Controller T6/7 / Schematic Diagrams

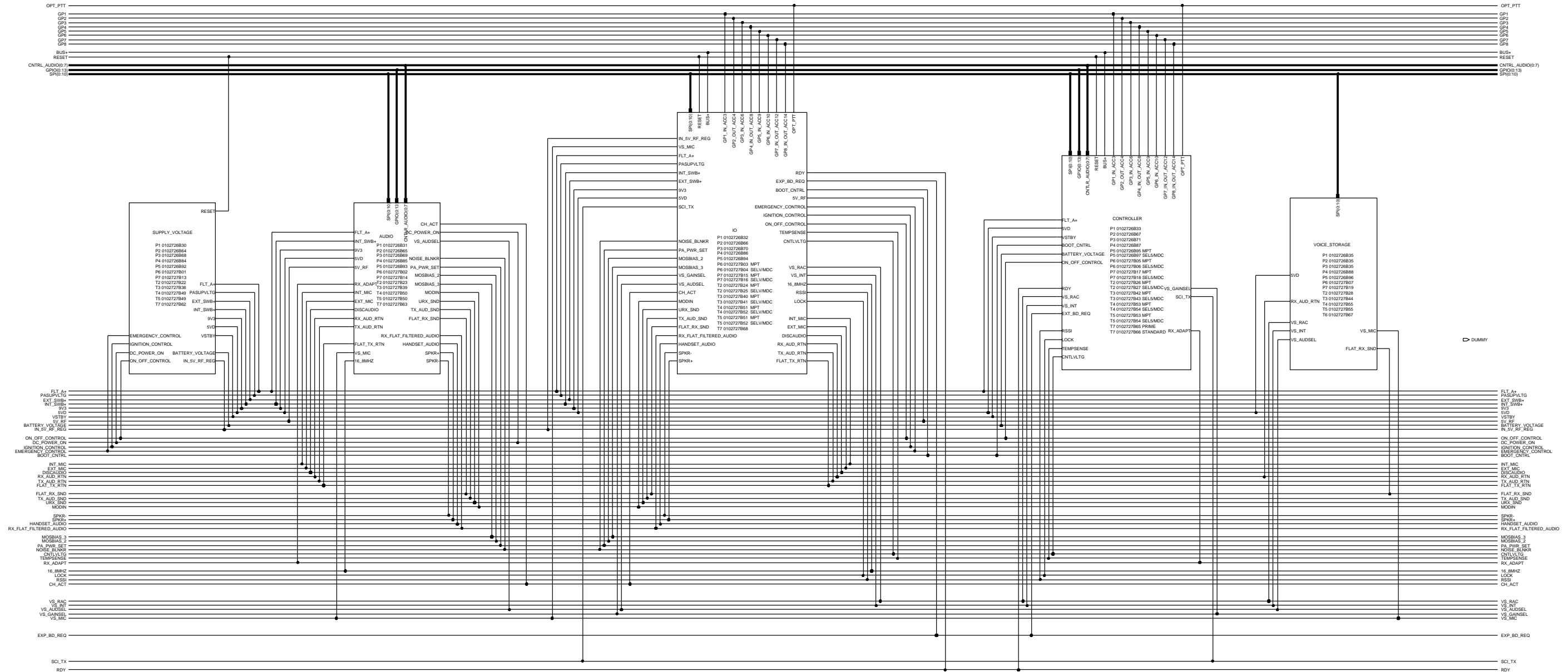

ZWG0130525-O

Controller T6/7 Schematic Diagram - Overall

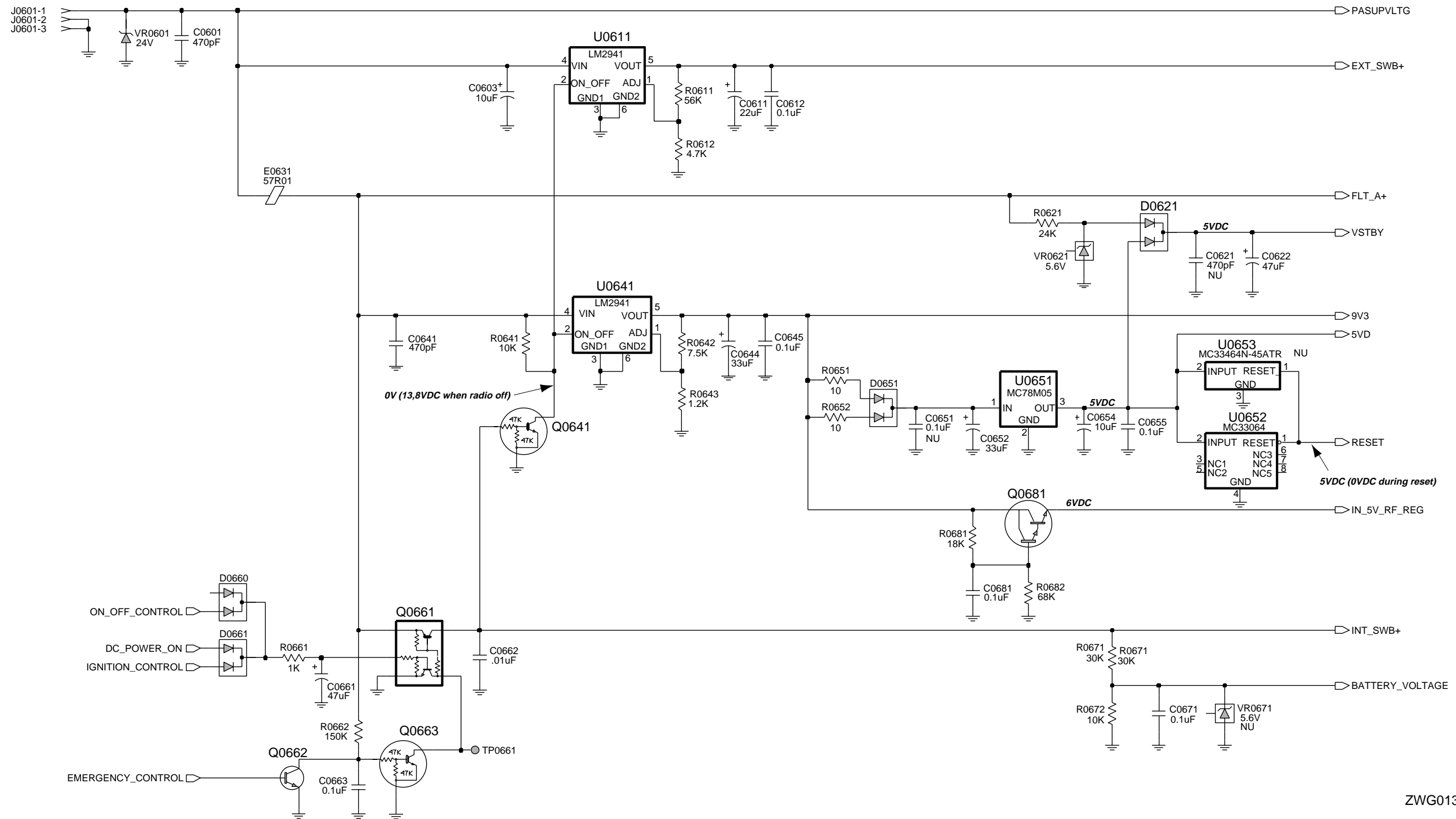

ZWG0130529-A

Controller T6/7 Schematic Diagram - Supply Voltage

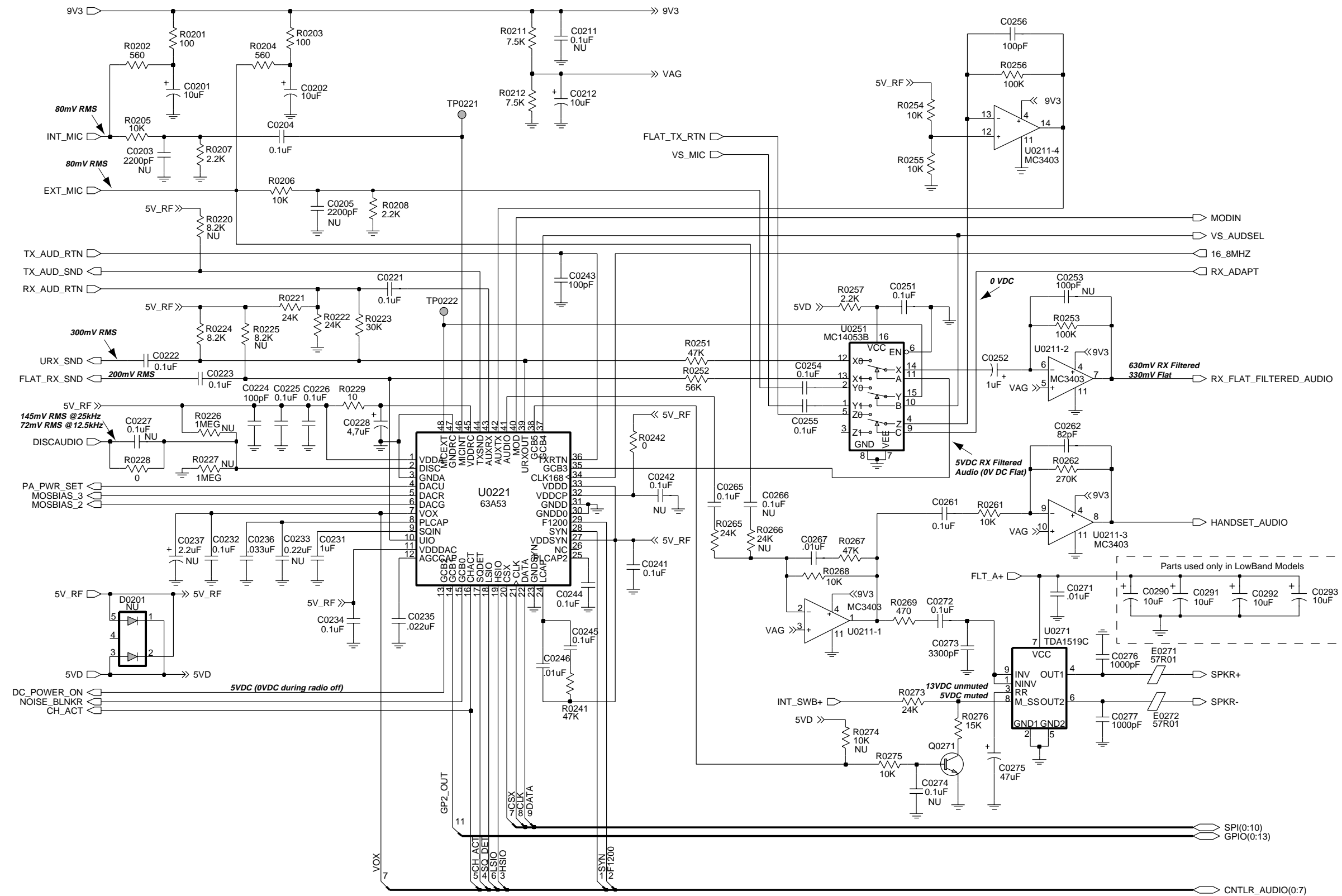

ZWG0130528-B

Controller T6/T7 Schematic Diagram - Audio

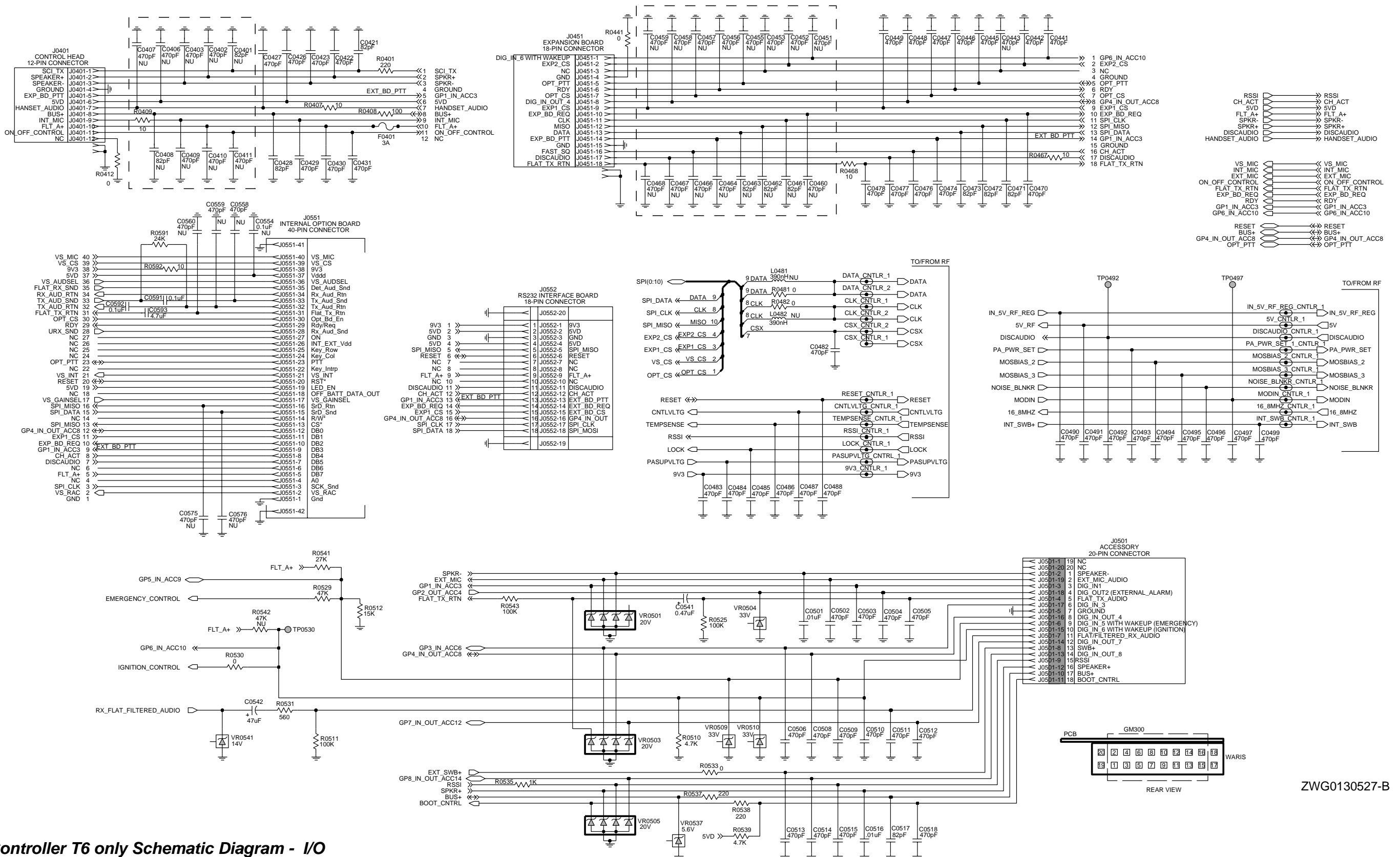

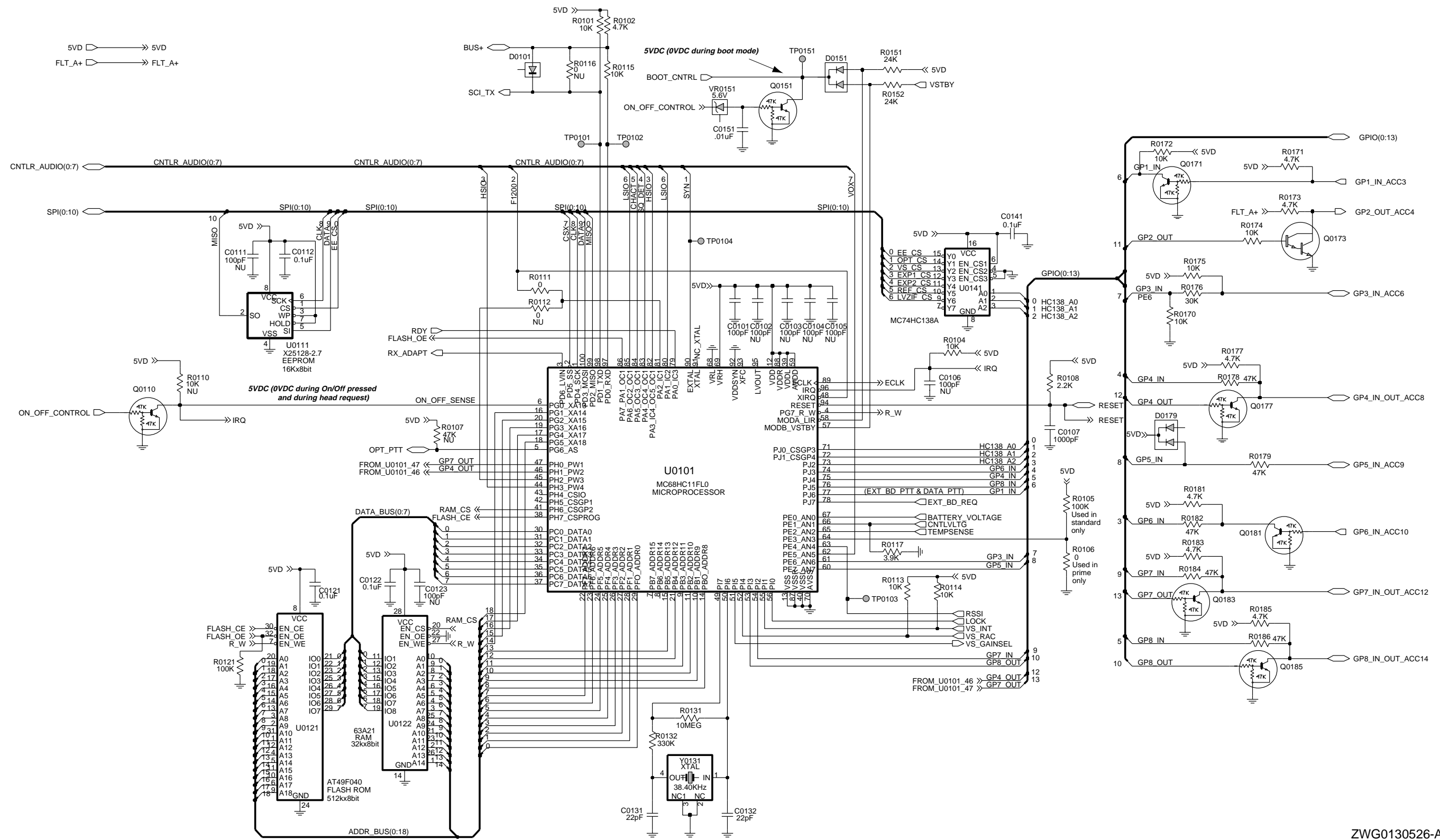

ZWG0130526-A

Controller T6/T7 Schematic Diagram - Microprocessor

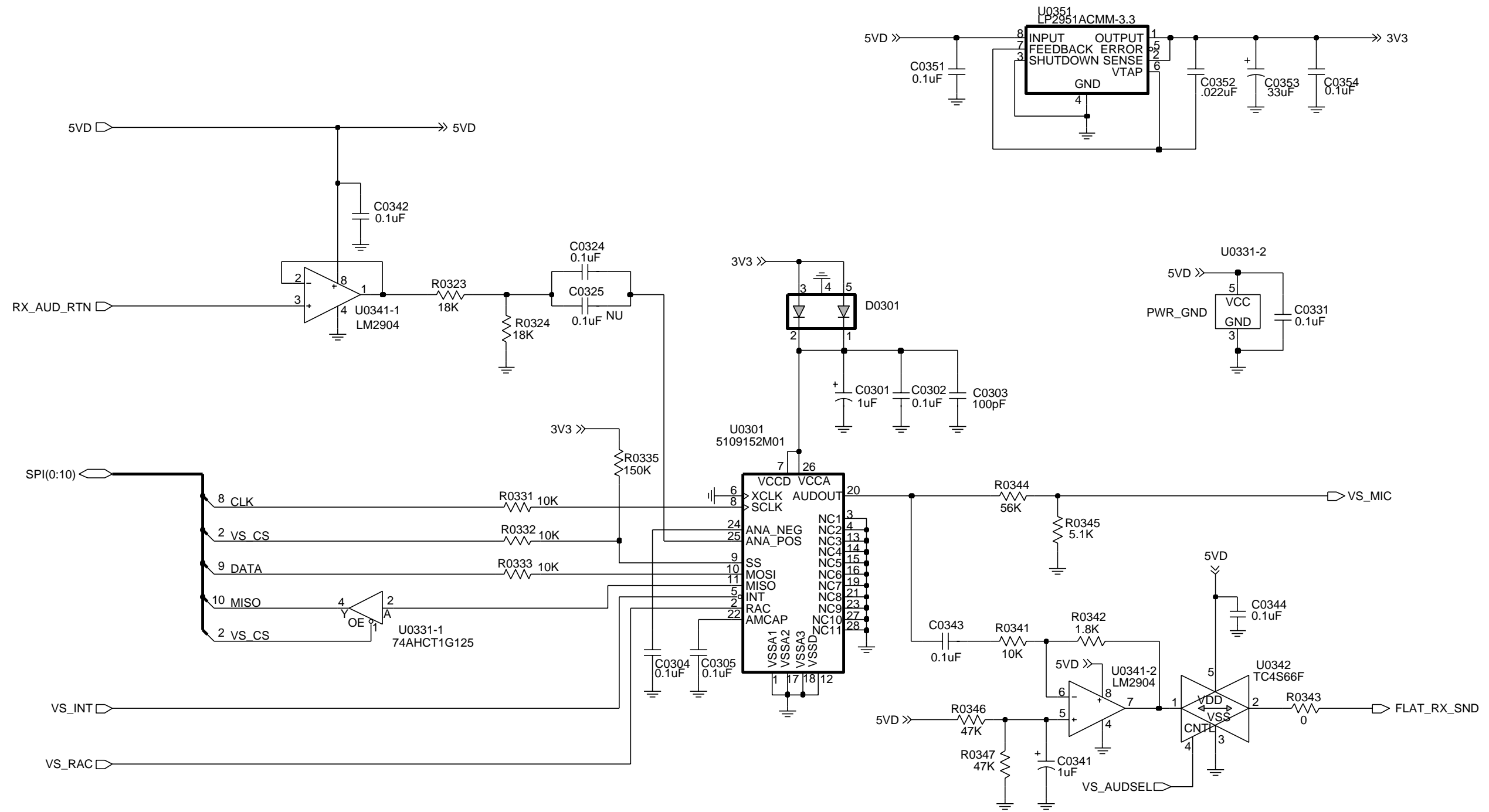

ZWG0130530-O

Controller T6/7 Schematic Diagram - Voice Storage

4.1 Controller T6/7 Parts List

Circuit Ref	Motorola Part No	Description
C0101	2113740F51	100pF 5% 50V
C0107	2113741F25	1nF 50V
C0112	2113743E20	100nF 16V
C0121	2113743E20	100nF 16V
C0122	2113743E20	100nF 16V
C0131	2113740F35	22pF 5% 50V
C0132	2113740F35	22pF 5% 50V
C0141	2113743E20	100nF 16V
C0151	2113741F49	10nF 50V
C0201	2311049A57	10uF 10% 16V
C0202	2311049A57	10uF 10% 16V
C0204	2113743E20	100nF 16V
C0212	2311049A57	10uF 10% 16V
C0221	2113743E20	100nF 16V
C0222	2113743E20	100nF 16V
C0223	2113743E20	100nF 16V
C0224	2113740F51	100pF 5% 50V
C0225	2113743E20	100nF 16V
C0226	2113743E20	100nF 16V
C0228	2311049A56	4.7uF 10% 16V
C0231	2113743B29	1 uF 10% 16V
C0232	2113743E20	100nF 16V
C0234	2113743E20	100nF 16V
C0235	2113743E07	22nF 16V
C0236	2113743E10	.033UF 10%
C0241	2113743E20	100nF 16V
C0243	2113740F51	100pF 5% 50V
C0244	2113743E20	100nF 16V
C0245	2113743E20	100nF 16V
C0246	2113741F49	10nF 50V
C0251	2113743E20	100nF 16V
Used in		CNTRL T7 only
C0252	2311049A07	1uF 10% 16V
C0254	2113743E20	100nF 16V
C0255	2113743E20	100nF 16V
C0256	2113740F51	100pF 5% 50V
C0261	2113743E20	100nF 16V
C0262	2113740F49	82pF 5% 50V NPO
C0265	2113743E20	100nF 16V
C0267	2113741F49	10nF 50V
C0271	2113741F49	10nF 50V
C0272	2113743E20	100nF 16V
C0273	2113741F37	3.3nF 50V
C0275	2311049A99	47uF 20% 10V
C0276	2113741F25	1nF 50V X7R
C0277	2113741F25	1nF 50V X7R
C0290	2311049C01	10uF (only LowBand)
C0291	2311049C01	10uF (only LowBand)
C0292	2311049C01	10uF (only LowBand)
C0293	2311049C01	10uF (only LowBand)

Circuit Ref	Motorola Part No	Description
C0301	2311049A07	TANT CP 1uF 10% 16V
Used in		GM1280 only
C0302	2113743E20	100nF 16V
Used in		GM1280 only
C0303	2113740F51	100pF 5% 50V
Used in		GM1280 only
C0304	2113743E20	100nF 16V
Used in		GM1280 only
C0305	2113743E20	100nF 16V
Used in		GM1280 only
C0324	2113743E20	100nF 16V
Used in		GM1280 only
C0331	2113743E20	100nF 16V
Used in		GM1280 only
C0341	2311049A07	TANT CP 1uF 10% 16V
Used in		GM1280 only
C0342	2113743E20	100nF 16V
Used in		GM1280 only
C0343	2113743E20	100nF 16V
Used in		GM1280 only
C0344	2113743E20	100nF 16V
Used in		GM1280 only
C0351	2113743E20	100nF 16V
Used in		GM1280 only
C0352	2113743E07	22nF 16V
Used in		GM1280 only
C0353	2311049A97	TANT CHIP 33 UF
Used in		GM1280 only
C0354	2113743E20	100nF 16V
Used in		GM1280 only
C0421	2113743N48	82.0 PF 5%
C0422	2113741F17	470pF 50V
C0423	2113741F17	470pF 50V
C0426	2113743L09	470 PF 10%
C0427	2113743L09	470 PF 10%
C0428	2113743N48	82.0 PF 5%
C0429	2113743L09	470 PF 10%
C0430	2113741F17	470pF 50V
C0431	2113741F17	470pF 50V
C0441	2113743L09	470 PF 10%
C0442	2113743L09	470 PF 10%
C0445	2113743L09	470 PF 10%
C0446	2113743L09	470 PF 10%
C0447	2113743L09	470 PF 10%
C0448	2113743L09	470 PF 10%
C0449	2113743L09	470 PF 10%
C0470	2113743L09	470 PF 10%
C0471	2113743N48	82.0 PF 5%
C0472	2113743N48	82.0 PF 5%
C0473	2113743N48	82.0 PF 5%
C0474	2113743L09	470 PF 10%
C0476	2113743L09	470 PF 10%
C0477	2113743L09	470 PF 10%

Circuit Ref	Motorola Part No	Description
C0478	2113743L09	470 PF 10%
C0482	2113743L09	470 PF 10%
C0483	2113743L09	470 PF 10%
C0484	2113741F17	470pF 50V
C0485	2113743L09	470 PF 10%
C0486	2113743L09	470 PF 10%
C0487	2113743L09	470 PF 10%
C0488	2113743L09	470 PF 10%
C0490	2113743L09	470 PF 10%
C0491	2113743L09	470 PF 10%
C0492	2113743L09	470 PF 10%
C0493	2113743L09	470 PF 10%
C0494	2113743L09	470 PF 10%
C0495	2113743L09	470 PF 10%
C0496	2113743L09	470 PF 10%
C0497	2113743L09	470 PF 10%
C0499	2113743L09	470 PF 10%
C0501	2113741F49	10nF 50V
C0502	2113743L09	470pF 10% (CNTRL T6)
C0502	2113741F17	470pF 50V (CNTRL T7)
C0503	2113743L09	470pF 10% (CNTRL T6)
C0503	2113741F17	470pF 50V (CNTRL T7)
C0504	2113741F17	470pF 50V
C0505	2113743L09	470pF 10% (CNTRL T6)
C0505	2113741F17	470pF 50V (CNTRL T7)
C0506	2113743L09	470pF 10% (CNTRL T6)
C0506	2113741F17	470pF 50V (CNTRL T7)
C0508	2113743L09	470pF 10% (CNTRL T6)
C0508	2113741F17	470pF 50V (CNTRL T7)
C0509	2113743L09	470pF 10% (CNTRL T6)
C0509	2113741F17	470pF 50V (CNTRL T7)
C0510	2113741F17	470pF 50V
C0511	2113743L09	470pF 10% (CNTRL T6)
C0511	2113741F17	470pF 50V (CNTRL T7)
C0512	2113743L09	470pF 10% (CNTRL T6)
C0512	2113741F17	470pF 50V (CNTRL T7)
C0513	2113741F17	470pF 50V
C0514	2113743L09	470pF 10% (CNTRL T6)
C0514	2113741F17	470pF 50V (CNTRL T7)
C0515	2113743L09	470pF 10% (CNTRL T6)
C0515	2113741F17	470pF 50V (CNTRL T7)
C0516	2113741F49	10nF 50V
C0517	2113743N48	82.0 PF 5%
C0518	2113743L09	470pF 10% (CNTRL T6)
C0518	2113741F17	470pF 50V (CNTRL T7)
C0541	2311049A05	470nF 10% 25V
C0542	2311049A99	47uF 20% 10V
C0591	2113743E20	100nF 16V
C0592	2113743E20	100nF 16V
C0593	2113741B69	100nF 50V
C0601	2113741F17	470pF 50V

Circuit Ref	Motorola Part No	Description
C0603	2380090M24	LYT 10uF 50V 20%
C0611	2311049C06	CP 22uF 20% 35V
C0612	2113743E20	100nF 16V
C0622	2311049A99	CP 47uF 20%
C0641	2113741F17	470pF 50V
C0644	2311049A97	CHIP 33 UF
C0645	2113743E20	100nF 16VD
C0652	2311049A97	CHIP 33 UF 16
C0654	2311049A57	CP 10uF 10% 16V
C0655	2113743E20	100nF 16V
C0661	2311049C05	CP 47uF 10% 16V
C0662	2113741F49	10nF 50V
C0663	2113743E20	100nF 16V
C0671	2113743E20	100nF 16V
C0681	2113743E20	100nF 16V
D0101	4880236E05	CHIP SCHOTTKY
D0151	4813833C02	DUAL SOT MMBD6100
D0179	4813833C02	DUAL SOT MMBD6100
D0301	4802245J47	SCHOTTKY BARRIER
Used in		GM1280 only (RB471E)
D0621	4813833C02	DUAL SOT MMBD6100
D0651	4813833C02	DUAL SOT MMBD6100
D0660	4813833C02	DUAL SOT MMBD6100
D0661	4813833C02	DUAL SOT MMBD6100
E0271	2484657R01	Ferrite Bead
E0272	2484657R01	Ferrite Bead
E0631	2484657R01	Ferrite Bead
F0401	6580542Z01	3A 24V
J0401	0902636Y02	CONN FLEX 12 PIN
J0451	0902636Y01	CONN FLEX SIDE ENTRY
J0501	0986105B01	CONN SMD 20 PIN
J0551	0905505Y04	CONN ZIF HORIZONTAL
J0552	0905505Y03	CONN ZIF 18PIN
J0601	0986165B01	DC PWR CONN
Q0110	4880048M01	NPN DIG 47k/47k
Q0151	4880048M01	NPN DIG 47k/47k
Q0171	4880048M01	NPN DIG 47k/47k
Q0173	4880052M01	NPN DRLNGTN MXTA
Q0177	4880048M01	NPN DIG 47k/47k
Q0181	4880048M01	NPN DIG 47k/47k
Q0183	4880048M01	NPN DIG 47k/47k
Q0185	4880048M01	NPN DIG 47k/47k
Q0271	4813824A10	NPN 40V .2A
Q0641	4880048M01	NPN DIG 47k/47k
Q0661	4805921T02	DUAL ROHM FMC2 RH
Q0662	4813824A10	NPN 40V .2A B=50-150
Q0663	4880048M01	NPN DIG 47k/47k
Q0681	4880052M01	NPN DRLNGTN MXTA
R0101	0662057A73	10k 1/16W 5%
R0102	0662057A65	4k7 1/16W 5%
R0104	0662057A73	10k 1/16W 5%

Circuit Ref	Motorola Part No	Description
R0105	0662057A97	100k 1/16W
Used in	GM140/160	GM340/360/640/660 only
R0106	0662057B47	0 1/16W
Used in		GM380/GM1280 only
R0108	0662057A57	2k2 1/16W 5%
R0111	0662057B47	0 1/16W 0306
R0113	0662057A73	10k 1/16W 5%
R0114	0662057A73	10k 1/16W 5%
R0115	0662057A73	10k 1/16W 5%
R0117	0662057A63	3k9 1/16W 5%
R0121	0662057A97	100k 1/16W
R0131	0662057B46	10.0 MEG OHMS 5%
R0132	0662057B10	330k 1/16W 5%
R0151	0662057A82	24K 1/16W 5%
R0152	0662057A82	24K 1/16W 5%
R0170	0662057A73	10k 1/16W 5%
R0171	0662057A65	4k7 1/16W 5%
R0172	0662057A73	10k 1/16W 5%
R0173	0662057A65	4k7 1/16W 5%
R0174	0662057A73	10k 1/16W 5%
R0175	0662057A73	10k 1/16W 5%
R0176	0662057A84	30k 1/16W 5%
R0177	0662057A65	4k7 1/16W 5%
R0178	0662057A89	47k 1/16W 5%
R0179	0662057A89	47k 1/16W 5%
R0181	0662057A65	4k7 1/16W 5%
R0182	0662057A89	47k 1/16W 5%
R0183	0662057A65	4k7 1/16W 5%
R0184	0662057A89	47k 1/16W 5%
R0185	0662057A65	4k7 1/16W 5%
R0186	0662057A89	47k 1/16W 5%
R0201	0662057A25	100 1/16W 5%
R0202	0662057A43	560 1/16W 5%
R0203	0662057A25	100 1/16W 5%
R0204	0662057A43	560 1/16W 5%
R0205	0662057A73	10k 1/16W 5%
R0206	0662057A73	10k 1/16W 5%
R0207	0662057A57	2k2 1/16W 5%
R0208	0662057A57	2k2 1/16W 5%
R0211	0660076E70	FILM 7500
R0212	0660076E70	FILM 7500
R0221	0662057A82	24K 1/16W 5%
R0222	0662057A82	24K 1/16W 5%
R0223	0662057A84	30k 1/16W 5%
R0224	0662057A71	8k2 1/16W 5%
R0228	0662057B47	0 1/16W
R0229	0662057A01	10 1/16W 5%
R0241	0662057A89	47k 1/16W 5%
R0242	0662057B47	0 1/16W
R0251	0662057A89	47k 1/16W 5%
R0252	0662057A91	56K 1/16W 5%

Circuit Ref	Motorola Part No	Description
R0253	0662057A97	100k 1/16W
R0254	0662057A73	10k 1/16W 5% (CNTRL T7 only)
R0255	0662057A73	10k 1/16W 5% (CNTRL T7 only)
R0256	0662057A97	100k 1/16W (CNTRL T7 only)
R0257	0662057A57	2k2 1/16W 5% (CNTRL T7 only)
R0261	0662057A73	10k 1/16W 5%
R0262	0662057A97	100k 1/16W
R0265	0662057A82	24K 1/16W 5%
R0267	0662057A89	47k 1/16W 5%
R0268	0662057A73	10k 1/16W 5%
R0269	0662057A41	470 1/16W 5%
R0273	0662057A82	24K 1/16W 5%
R0275	0662057A73	10k 1/16W 5%
R0276	0662057A77	15k 1/16W 5%
R0323	0662057A79	18k 1/16W 5%
Used in	GM1280 only	
R0324	0662057A79	18k 1/16W 5%
Used in	GM1280 only	
R0331	0662057A73	10k 1/16W 5%
Used in	GM1280 only	
R0332	0662057A73	10k 1/16W 5%
Used in	GM1280 only	
R0333	0662057A73	10k 1/16W 5%
Used in	GM1280 only	
R0335	0662057B02	150k 1/16W
Used in	GM1280 only	
R0341	0662057A73	10k 1/16W
Used in	GM1280 only	
R0342	0662057A55	1k8 1/16W
Used in	GM1280 only	
R0343	0662057B47	0 1/16W
Used in	GM1280 only	
R0344	0662057A91	56K 1/16W
Used in	GM1280 only	
R0345	0662057A66	5k1 1/16W
Used in	GM1280 only	
R0346	0662057A89	47k 1/16W
Used in	GM1280 only	
R0347	0662057A89	47k 1/16W
Used in	GM1280 only	
R0401	0662057A33	220 1/16W
R0407	0662057M26	10 5% 20X40
R0408	0662057A25	100 1/16W 5%
R0409	0662057M26	10 5% 20X40
R0412	0662057B47	0 1/16W
R0441	0662057B47	0 1/16W
R0442	0662057A49	1k 1/16W 5%
Used in		CNTRL T7 only
R0467	0662057M26	10 5% 20X40

Circuit Ref	Motorola Part No	Description
R0468	0662057M26	10 5% 20X40 (CNTRL T6)
R0468	0662057A97	100k 1/16W (CNTRL T7)
R0481	0662057B47	0 1/16W
R0482	0662057B47	0 1/16W
R0510	0662057A65	4k7 1/16W 5%
R0511	0662057A97	100k 1/16W
R0512	0662057A77	15k 1/16W 5%
R0525	0662057A97	100k 1/16W
R0529	0662057A89	47k 1/16W 5%
R0530	0662057B47	0 1/16W
R0531	0662057A43	560 1/16W 5%
R0533	0662057B47	0 1/16W
R0535	0662057A49	1k 1/16W 5%
R0537	0662057A33	220 1/16W 5%
R0538	0662057A33	220 1/16W 5%
R0539	0662057A65	4k7 1/16W 5%
R0541	0662057A83	27k 1/16W 5%
R0543	0662057A97	100k 1/16W (CNTRL T7 only)
R0591	0662057A82	24K 1/16W 5%
R0592	0662057A01	10 1/16W 5%
R0593	0662057A97	100k 1/16W (CNTRL T7 only)
R0611	0662057A91	56K 1/16W
R0612	0662057A65	4k7 1/16W
R0621	0662057A82	24K 1/16W
R0641	0662057A73	10k 1/16W
R0642	0660076E70	FILM 7500
R0643	0660076E51	FILM 1200
R0651	0662057A01	10 1/16W 5%
R0652	0662057A01	10 1/16W 5%
R0661	0662057A49	1k 1/16W 5%
R0662	0662057B02	150k 1/16W
R0671	0662057A84	30k 1/16W 5%
R0672	0662057A73	10k 1/16W 5%
R0681	0662057A79	18k 1/16W 5%
R0682	0662057A93	68k 1/16W 5%
U0101	5102226J56	MICRO PROCESSOR MC68HC1 1FLO
* U0111	5102463J64	EEPROM X25128-2.7 SO8
* U0121	5186137B01	512KX8 FLASH ROM (AT49BV020)
U0122	5185963A21	32K x 8 SRAM
U0141	5113805A30	10F8 DCDR/REMUX 74HC138
U0211	5183222M49	QUAD OPAMP __3403
U0221	5185130C53	ASFICCOMP 0.5MM TQFP
U0251	5113806A20	MUX/DEMUX,TRIPLE 2-
U0271	5109699X01	AUDIO PA TDA1519C
U0301	5109152M01	EEPROM ANALOG
Used in	GM1280 only	ISD33120EI

Circuit Ref	Motorola Part No	Description
U0331	5186204B01	BUFFER/DRIVER
Used in	GM1280 only	74AHCT1G125
U0341	5180932W01	LINEAR IC OP AMP
Used in	GM1280 only	
U0342	5105750U28	SNGL ANALOG SWITCH
Used in	GM1280 only	SMD
U0351	5102463J40	REGULATOR, 3.3V,
Used in	GM1280 only	LP2951CM-3.3
U0611	5183308X01	ADJ VLTG REG LM2941
		TO263
U0641	5183308X01	ADJ VLTG REG LM2941
		TO263
U0651	5113816A07	REG 5V POS 500MA
		MC78M05
U0652	5113815A02	MC33064
VR0151	4813830A15	5.6V 5% 225mW
VR0501	4805656W09	ZENER QUAD MMQA20VT1
VR0503	4805656W09	ZENER QUAD MMQA20VT1
VR0504	4813830A40	SOC23 AUTO SDN
VR0505	4805656W09	ZENER QUAD MMQA20VT1
VR0509	4813830A40	SOC23 AUTO SDN
VR0510	4813830A40	SOC23 AUTO SDN
VR0537	4813830A15	5.6V 5% 225mW
VR0541	4813830A27	14V 5% 225MW
VR0601	4813832C77	TRANS SUP. 24V HIGH
		POWER
VR0621	4813830A15	5.6V 5% 225mW
Y0131	4880113R19	CRYSTAL 38.4KHz

* Motorola Depot Servicing only

Reference designators with an asterisk indicate components which are not fieldreplaceable because they need to be calibrated with specialized factory equipment after installation. Radios in which these parts have been replaced in the field will be off frequency at temperature extremes.

5.0 Controller T9 / Schematic Diagrams

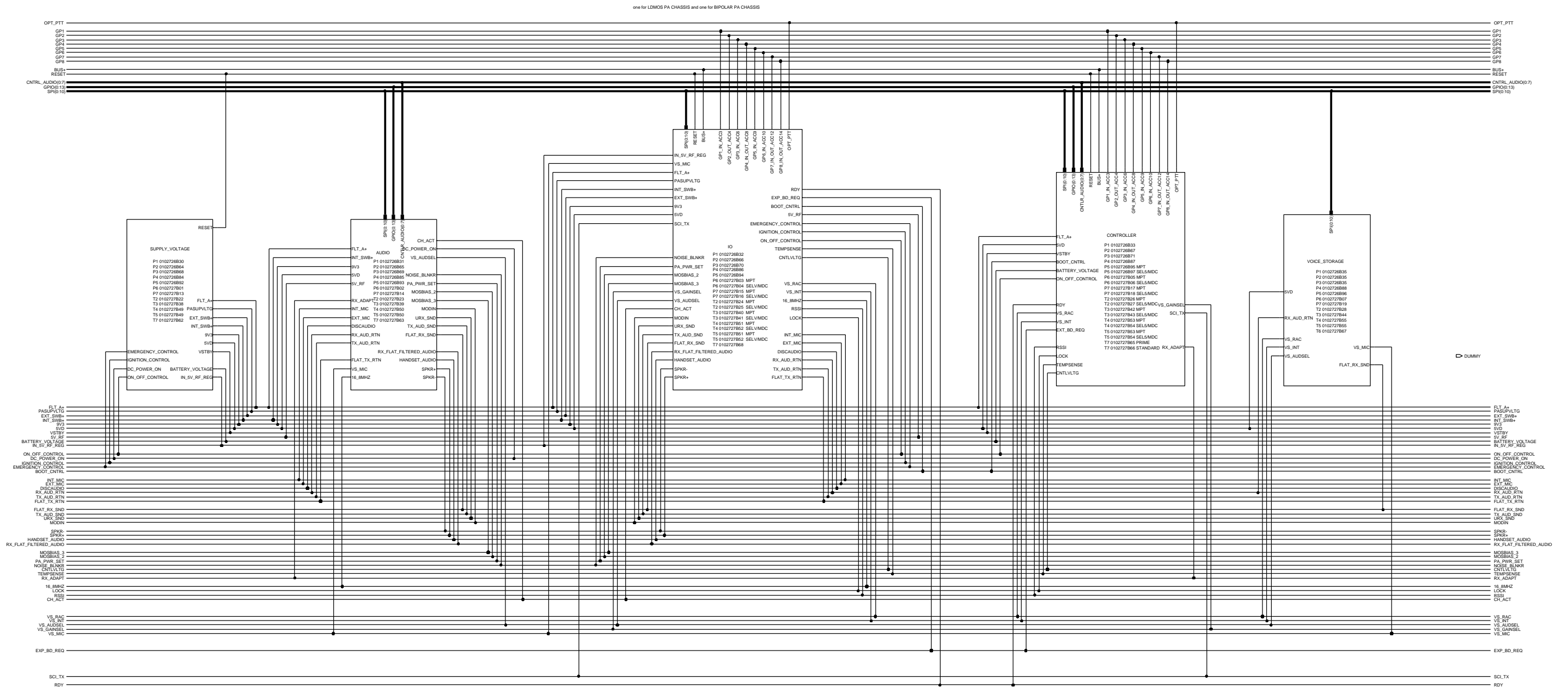

ZWG0130525-O

Controller T9 Schematic Diagram - Overall

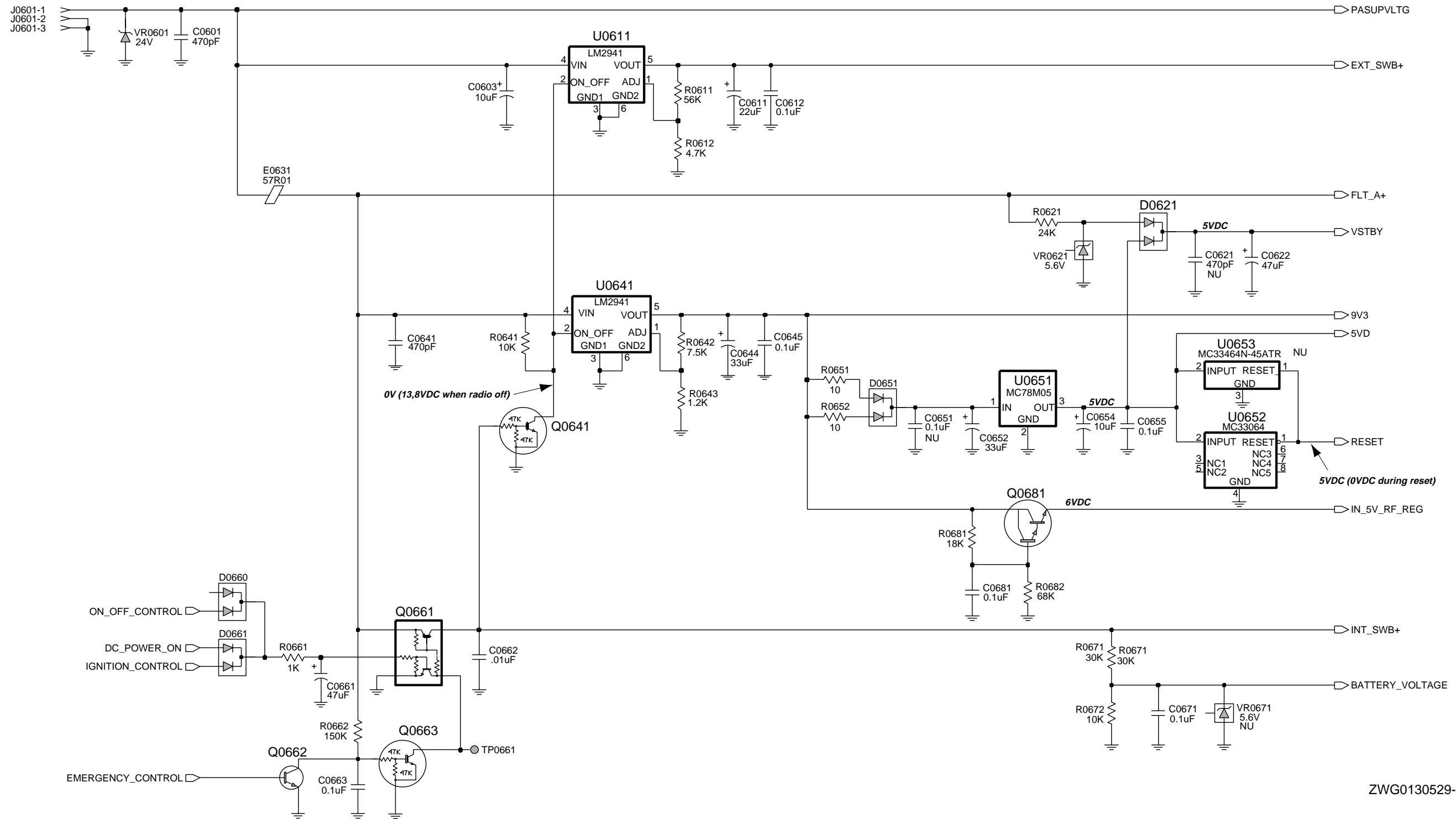

ZWG0130529-A

Controller T9 Schematic Diagram - Supply Voltage

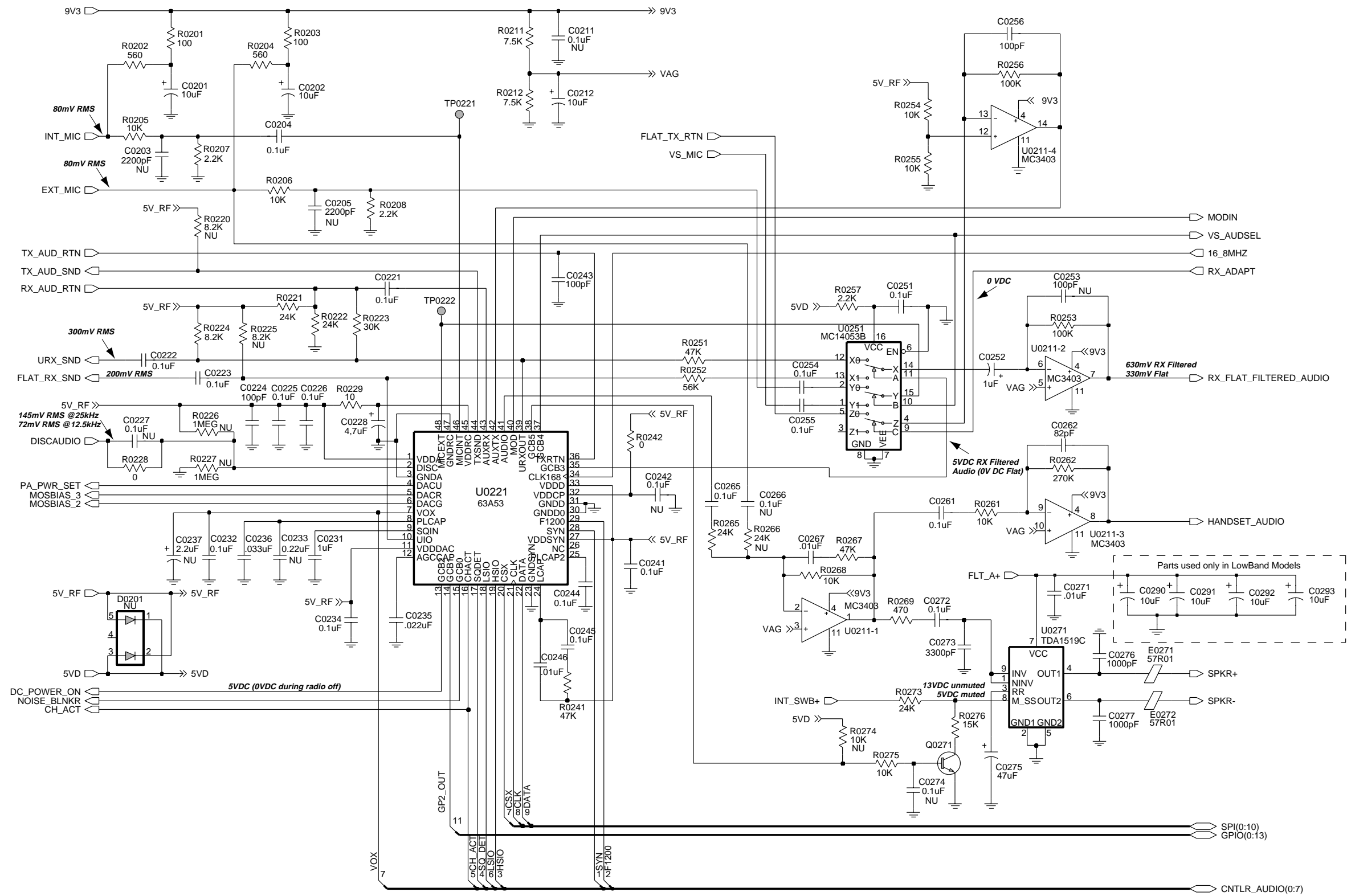

ZWG0130528-B

Controller T9 Schematic Diagram - Audio PA

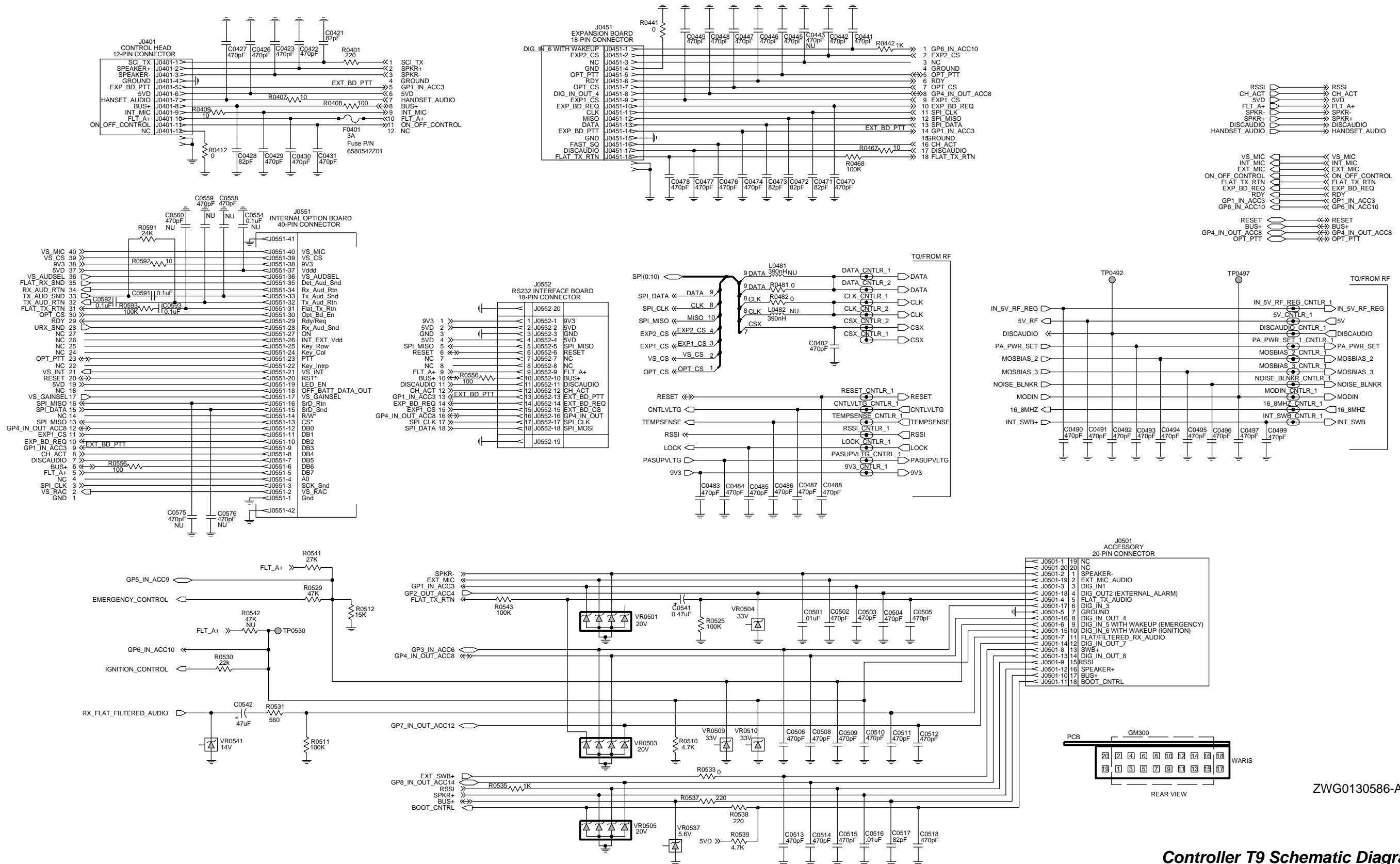

Controller T9 Schematic Diagram - I/O

ZWG0130586-A

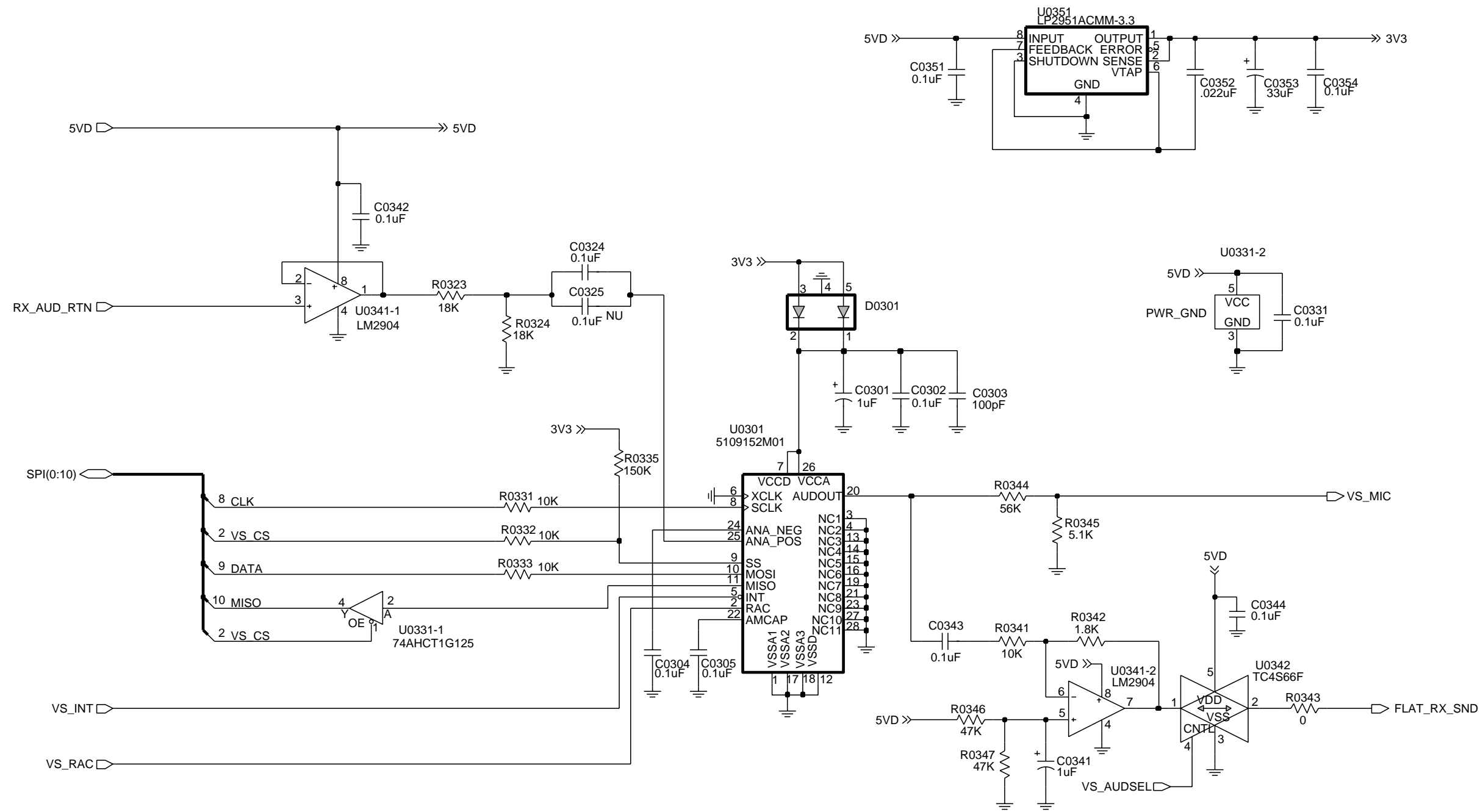

ZWG0130530-O

Controller T9 Schematic Diagram - Voice Storage

5.1 Controller T9 Parts List

Circuit Ref	Motorola Part No	Description
C0101	2113740F51	100pF 5% 50V
C0107	2113741F25	1nF 50V
C0112	2113743E20	100nF 16V
C0121	2113743E20	100nF 16V
C0122	2113743E20	100nF 16V
C0131	2113740F35	22pF 5% 50V
C0132	2113740F35	22pF 5% 50V
C0141	2113743E20	100nF 16V
C0151	2113741F49	10nF 50V
C0201	2311049A57	10uF 10% 16V
C0202	2311049A57	10uF 10% 16V
C0204	2113743E20	100nF 16V
C0212	2311049A57	10uF 10% 16V
C0221	2113743E20	100nF 16V
C0222	2113743E20	100nF 16V
C0223	2113743E20	100nF 16V
C0224	2113740F51	100pF 5% 50V
C0225	2113743E20	100nF 16V
C0226	2113743E20	100nF 16V
C0228	2311049A56	4.7uF 10% 16V
C0231	2113743B29	1 uF 10% 16V
C0232	2113743E20	100nF 16V
C0234	2113743E20	100nF 16V
C0235	2113743E07	22nF 16V
C0236	2113743E10	.033UF 10%
C0241	2113743E20	100nF 16V
C0243	2113740F51	100pF 5% 50V
C0244	2113743E20	100nF 16V
C0245	2113743E20	100nF 16V
C0246	2113741F49	10nF 50V
C0251	2113743E20	100nF 16V
C0252	2311049A07	1uF 10% 16V
C0254	2113743E20	100nF 16V
C0255	2113743E20	100nF 16V
C0256	2113740F51	100pF 5% 50V
C0261	2113743E20	100nF 16V
C0262	2113740F49	82pF 5% 50V NPO
C0265	2113743E20	100nF 16V
C0267	2113741F49	10nF 50V
C0271	2113741F49	10nF 50V
C0272	2113743E20	100nF 16V
C0273	2113741F37	3.3nF 50V
C0275	2311049A99	47uF 20% 10V
C0276	2113741F25	1nF 50V X7R
C0277	2113741F25	1nF 50V X7R
C0290	2311049C01	10uF (only LowBand)
C0291	2311049C01	10uF (only LowBand)
C0292	2311049C01	10uF (only LowBand)
C0293	2311049C01	10uF (only LowBand)

Circuit Ref	Motorola Part No	Description
C0301	2311049A07	TANT CP 1uF 10% 16V
Used in	GM1280 only	
C0302	2113743E20	100nF 16V
Used in	GM1280 only	
C0303	2113740F51	100pF 5% 50V
Used in	GM1280 only	
C0304	2113743E20	100nF 16V
Used in	GM1280 only	
C0305	2113743E20	100nF 16V
Used in	GM1280 only	
C0324	2113743E20	100nF 16V
Used in	GM1280 only	
C0331	2113743E20	100nF 16V
Used in	GM1280 only	
C0341	2311049A07	TANT CP 1uF 10% 16V
Used in	GM1280 only	
C0342	2113743E20	100nF 16V
Used in	GM1280 only	
C0343	2113743E20	100nF 16V
Used in	GM1280 only	
C0344	2113743E20	100nF 16V
Used in	GM1280 only	
C0351	2113743E20	100nF 16V
Used in	GM1280 only	
C0352	2113743E07	22nF 16V
Used in	GM1280 only	
C0353	2311049A97	TANT CHIP 33 UF
Used in	GM1280 only	
C0354	2113743E20	100nF 16V
Used in	GM1280 only	
C0421	2113743N48	82.0 PF 5%
C0422	2113741F17	470pF 50V
C0423	2113741F17	470pF 50V
C0426	2113743L09	470 PF 10%
C0427	2113743L09	470 PF 10%
C0428	2113743N48	82.0 PF 5%
C0429	2113743L09	470 PF 10%
C0430	2113741F17	470pF 50V
C0431	2113741F17	470pF 50V
C0441	2113743L09	470 PF 10%
C0442	2113743L09	470 PF 10%
C0445	2113743L09	470 PF 10%
C0446	2113743L09	470 PF 10%
C0447	2113743L09	470 PF 10%
C0448	2113743L09	470 PF 10%
C0449	2113743L09	470 PF 10%
C0470	2113743L09	470 PF 10%
C0471	2113743N48	82.0 PF 5%
C0472	2113743N48	82.0 PF 5%
C0473	2113743N48	82.0 PF 5%
C0474	2113743L09	470 PF 10%
C0476	2113743L09	470 PF 10%
C0477	2113743L09	470 PF 10%

Circuit Ref	Motorola Part No	Description
C0478	2113743L09	470 PF 10%
C0482	2113743L09	470 PF 10%
C0483	2113743L09	470 PF 10%
C0484	2113741F17	470pF 50V
C0485	2113743L09	470 PF 10%
C0486	2113743L09	470 PF 10%
C0487	2113743L09	470 PF 10%
C0488	2113743L09	470 PF 10%
C0490	2113743L09	470 PF 10%
C0491	2113743L09	470 PF 10%
C0492	2113743L09	470 PF 10%
C0493	2113743L09	470 PF 10%
C0494	2113743L09	470 PF 10%
C0495	2113743L09	470 PF 10%
C0496	2113743L09	470 PF 10%
C0497	2113743L09	470 PF 10%
C0499	2113743L09	470 PF 10%
C0501	2113741F49	10nF 50V
C0502	2113741F17	470pF 50V
C0503	2113741F17	470pF 50V
C0504	2113741F17	470pF 50V
C0505	2113741F17	470pF 50V
C0506	2113741F17	470pF 50V
C0508	2113741F17	470pF 50V (
C0509	2113741F17	470pF 50V
C0510	2113741F17	470pF 50V
C0511	2113741F17	470pF 50V
C0512	2113741F17	470pF 50V
C0513	2113741F17	470pF 50V
C0514	2113741F17	470pF 50V
C0515	2113741F17	470pF 50V
C0516	2113741F49	10nF 50V
C0517	2113743N48	82.0 PF 5%
C0518	2113741F17	470pF 50V
C0541	2311049A05	470nF 10% 25V
C0542	2311049A99	47uF 20% 10V
C0560	2113743L17	1nF 10%
C0591	2113743E20	100nF 16V
C0592	2113743E20	100nF 16V
C0593	2113741B69	100nF 50V
C0601	2113741F17	470pF 50V
C0603	2380090M24	LYT 10uF 50V 20%
C0611	2311049C06	CP 22uF 20% 35V
C0612	2113743E20	100nF 16V
C0622	2311049A99	CP 47uF 20%
C0641	2113741F17	470pF 50V
C0644	2311049A97	CHIP 33 UF
C0645	2113743E20	100nF 16VD
C0652	2311049A97	CHIP 33 UF 16
C0654	2311049A57	CP 10uF 10% 16V
C0655	2113743E20	100nF 16V

Circuit Ref	Motorola Part No	Description
C0661	2311049C05	CP 47uF 10% 16V
C0662	2113741F49	10nF 50V
C0663	2113743E20	100nF 16V
C0671	2113743E20	100nF 16V
C0681	2113743E20	100nF 16V
D0101	4813825A05	CHIP SCHOTTKY
D0151	4813833C02	DUAL SOT MMBD6100
D0179	4813833C02	DUAL SOT MMBD6100
D0301	4802245J47	SCHOTTKY BARRIER
Used in	GM1280 only	(RB471E)
D0621	4813833C02	DUAL SOT MMBD6100
D0651	4813833C02	DUAL SOT MMBD6100
D0660	4813833C02	DUAL SOT MMBD6100
D0661	4813833C02	DUAL SOT MMBD6100
E0271	2484657R01	Ferrite Bead
E0272	2484657R01	Ferrite Bead
E0631	2484657R01	Ferrite Bead
F0401	6580542Z01	3A 24V
J0401	0902636Y02	CONN FLEX 12 PIN
J0451	0902636Y01	CONN FLEX SIDE ENTRY
J0501	0986105B01	CONN SMD 20 PIN
J0551	0905505Y04	CONN ZIF HORIZONTAL
J0552	0905505Y03	CONN ZIF 18PIN
J0601	0986165B01	DC PWR CONN
Q0110	4880048M01	NPN DIG 47k/47k
Q0151	4880048M01	NPN DIG 47k/47k
Q0171	4880048M01	NPN DIG 47k/47k
Q0173	4880052M01	NPN DRLNGTN MXTA
Q0177	4880048M01	NPN DIG 47k/47k
Q0181	4880048M01	NPN DIG 47k/47k
Q0183	4880048M01	NPN DIG 47k/47k
Q0185	4880048M01	NPN DIG 47k/47k
Q0271	4880214G02	NPN 40V .2A
Q0641	4880048M01	NPN DIG 47k/47k
Q0661	4805921T02	DUAL ROHM FMC2 RH
Q0662	4880214G02	NPN 40V .2A
Q0663	4880048M01	NPN DIG 47k/47k
Q0681	4880052M01	NPN DRLNGTN MXTA
R0101	0662057A73	10k 1/16W 5%
R0102	0662057A65	4k7 1/16W 5%
R0103	0662057A01	10 1/16W 5%
R0104	0662057A73	10k 1/16W 5%
R0105	0662057A97	100k 1/16W
Used in	GM140/160	GM340/360/640/660 only
R0106	0662057B47	0 1/16W
Used in		GM380/GM1280 only
R0108	0662057A57	2k2 1/16W 5%
R0111	0662057B47	0 1/16W 0306
R0113	0662057A73	10k 1/16W 5%
R0114	0662057A73	10k 1/16W 5%
R0115	0662057A73	10k 1/16W 5%
R0117	0662057A63	3k9 1/16W 5%

Circuit Ref	Motorola Part No	Description
R0121	0662057A97	100k 1/16W
R0131	0662057B46	10.0 MEG OHMS 5%
R0132	0662057B10	330k 1/16W 5%
R0151	0662057A82	24K 1/16W 5%
R0152	0662057A82	24K 1/16W 5%
R0170	0662057A73	10k 1/16W 5%
R0171	0662057A65	4k7 1/16W 5%
R0172	0662057A73	10k 1/16W 5%
R0173	0662057A65	4k7 1/16W 5%
R0174	0662057A73	10k 1/16W 5%
R0175	0662057A73	10k 1/16W 5%
R0176	0662057A84	30k 1/16W 5%
R0177	0662057A65	4k7 1/16W 5%
R0178	0662057A89	47k 1/16W 5%
R0179	0662057A89	47k 1/16W 5%
R0181	0662057A65	4k7 1/16W 5%
R0182	0662057A89	47k 1/16W 5%
R0183	0662057A65	4k7 1/16W 5%
R0184	0662057A89	47k 1/16W 5%
R0185	0662057A65	4k7 1/16W 5%
R0186	0662057A89	47k 1/16W 5%
R0201	0662057A25	100 1/16W 5%
R0202	0662057A43	560 1/16W 5%
R0203	0662057A25	100 1/16W 5%
R0204	0662057A43	560 1/16W 5%
R0205	0662057A73	10k 1/16W 5%
R0206	0662057A73	10k 1/16W 5%
R0207	0662057A57	2k2 1/16W 5%
R0208	0662057A57	2k2 1/16W 5%
R0211	0660076E70	FILM 7500
R0212	0660076E70	FILM 7500
R0221	0662057A82	24K 1/16W 5%
R0222	0662057A82	24K 1/16W 5%
R0223	0662057A84	30k 1/16W 5%
R0224	0662057A71	8k2 1/16W 5%
R0228	0662057B47	0 1/16W
R0229	0662057A01	10 1/16W 5%
R0241	0662057A89	47k 1/16W 5%
R0242	0662057B47	0 1/16W
R0251	0662057A89	47k 1/16W 5%
R0252	0662057A91	56K 1/16W 5%
R0253	0662057A97	100k 1/16W
R0254	0662057A73	10k 1/16W 5%
R0255	0662057A73	10k 1/16W 5%
R0256	0662057A97	100k 1/16W
R0257	0662057A57	2k2 1/16W 5%
R0261	0662057A73	10k 1/16W 5%
R0262	0662057B08	270k 1/16W
R0265	0662057A82	24K 1/16W 5%
R0267	0662057A89	47k 1/16W 5%
R0268	0662057A73	10k 1/16W 5%

Circuit Ref	Motorola Part No	Description
R0269	0662057A41	470 1/16W 5%
R0273	0662057A82	24K 1/16W 5%
R0275	0662057A73	10k 1/16W 5%
R0276	0662057A77	15k 1/16W 5%
R0323	0662057A79	18k 1/16W 5%
Used in	GM1280 only	
R0324	0662057A79	18k 1/16W 5%
Used in	GM1280 only	
R0331	0662057A73	10k 1/16W 5%
Used in	GM1280 only	
R0332	0662057A73	10k 1/16W 5%
Used in	GM1280 only	
R0333	0662057A73	10k 1/16W 5%
Used in	GM1280 only	
R0335	0662057B02	150k 1/16W
Used in	GM1280 only	
R0341	0662057A73	10k 1/16W
Used in	GM1280 only	
R0342	0662057A55	1k8 1/16W
Used in	GM1280 only	
R0343	0662057B47	0 1/16W
Used in	GM1280 only	
R0344	0662057A91	56K 1/16W
Used in	GM1280 only	
R0345	0662057A66	5k1 1/16W
Used in	GM1280 only	
R0346	0662057A89	47k 1/16W
Used in	GM1280 only	
R0347	0662057A89	47k 1/16W
Used in	GM1280 only	
R0401	0662057A33	220 1/16W
R0407	0662057M26	10 5% 20X40
R0408	0662057A25	100 1/16W 5%
R0409	0662057M26	10 5% 20X40
R0412	0662057B47	0 1/16W
R0441	0662057B47	0 1/16W
R0442	0662057A49	1k 1/16W 5%
R0467	0662057M26	10 5% 20X40
R0468	0662057A97	100k 1/16W
R0481	0662057B47	0 1/16W
R0482	0662057B47	0 1/16W
R0510	0662057A65	4k7 1/16W 5%
R0511	0662057A97	100k 1/16W
R0512	0662057A77	15k 1/16W 5%
R0525	0662057A97	100k 1/16W
R0529	0662057A89	47k 1/16W 5%
R0530	0662057A81	22k 1/16W 5%
R0531	0662057A43	560 1/16W 5%
R0533	0662057B47	0 1/16W
R0535	0662057A49	1k 1/16W 5%
R0537	0662057A33	220 1/16W 5%
R0538	0662057A33	220 1/16W 5%

Circuit Ref	Motorola Part No	Description
R0539	0662057A65	4k7 1/16W 5%
R0541	0662057A83	27k 1/16W 5%
R0543	0662057A97	100k 1/16W
R0555	0662057A25	100 1/16W 5%
R0556	0662057A25	100 1/16W 5%
R0591	0662057A82	24K 1/16W 5%
R0592	0662057A01	10 1/16W 5%
R0593	0662057A97	100k 1/16W
R0611	0662057A91	56K 1/16W
R0612	0662057A65	4k7 1/16W
R0621	0662057A82	24K 1/16W
R0641	0662057A73	10k 1/16W
R0642	0660076E70	FILM 7500
R0643	0660076E51	FILM 1200
R0651	0662057A01	10 1/16W 5%
R0652	0662057A01	10 1/16W 5%
R0661	0662057A49	1k 1/16W 5%
R0662	0662057B02	150k 1/16W
R0671	0662057A84	30k 1/16W 5%
R0672	0662057A73	10k 1/16W 5%
R0681	0662057A79	18k 1/16W 5%
R0682	0662057A93	68k 1/16W 5%
U0101	5102226J56	MICRO PROCESSOR MC68HC1 1FLO
* U0111	5102463J64	EEPROM X25128-2.7 SO8
* U0121	5186137B01	512KX8 FLASH ROM (AT49BV020)
U0122	5185748L01	32K x 8 SRAM
U0141	5113805A30	10F8 DCDR/REMUX 74HC138
U0211	5183222M49	QUAD OPAMP __ 3403
U0221	5185130C53	ASFICCOMP 0.5MM TQFP
U0251	5184704M60	MUX/DEMUX,TRIPLE 2-
U0271	5109699X01	AUDIO PA TDA1519C
U0301	5109152M01	EEPROM ANALOG
Used in	GM1280 only	ISD33120EI
U0331	5186204B01	BUFFER/DRIVER
Used in	GM1280 only	74AHCT1G125
U0341	5180932W01	LINEAR IC OP AMP
Used in	GM1280 only	
U0342	5105750U28	SNGL ANALOG SWITCH
Used in	GM1280 only	SMD
U0351	5102463J40	REGULATOR, 3.3V,
Used in	GM1280 only	LP2951CM-3.3
U0611	5183308X01	ADJ VLTG REG LM2941 TO263
U0641	5183308X01	ADJ VLTG REG LM2941 TO263
U0651	5113816A07	REG 5V POS 500MA MC78M05
U0652	5113815A02	MC33064
VR0151	4813830A15	5.6V 5% 225mW

Circuit Ref	Motorola Part No	Description
VR0501	4805656W09	ZENER QUAD MMQA20VT1
VR0503	4805656W09	ZENER QUAD MMQA20VT1
VR0504	4813830A40	SOC23 AUTO SDN
VR0505	4805656W09	ZENER QUAD MMQA20VT1
VR0509	4813830A40	SOC23 AUTO SDN
VR0510	4813830A40	SOC23 AUTO SDN
VR0537	4813830A15	5.6V 5% 225mW
VR0541	4813830A27	14V 5% 225MW
VR0601	4813832C77	TRANS SUP. 24V HIGH POWER
VR0621	4813830A15	5.6V 5% 225mW
Y0131	4880113R19	CRYSTAL 38.4KHz

* Motorola Depot Servicing only

Reference designators with an asterisk indicate components which are not fieldreplaceable because they need to be calibrated with specialized factory equipment after installation. Radios in which these parts have been replaced in the field will be off frequency at temperature extremes.

6.0 Controller T11 / Schematic Diagrams

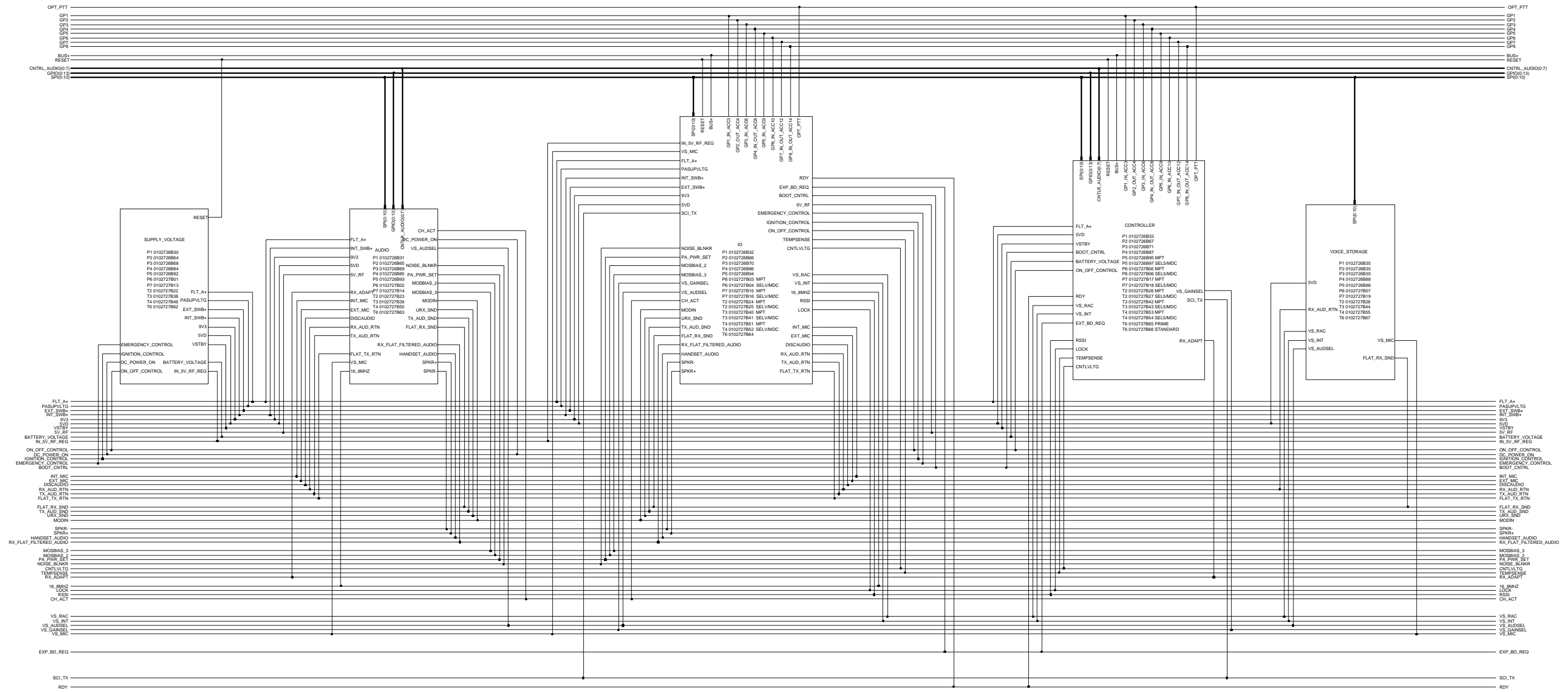

Controller Module Versions Changes						
	T4	T5	T6	T7	T8	T9
Suppl Vltg	X	X	-	-	X	-
Audio	X	X	-	X	X	-
IO	X	X	-	X	X	X
CONTLR	X	X	-	-	-	X
Voice Str.	-	-	-	-	-	-

ZWG0130934-O

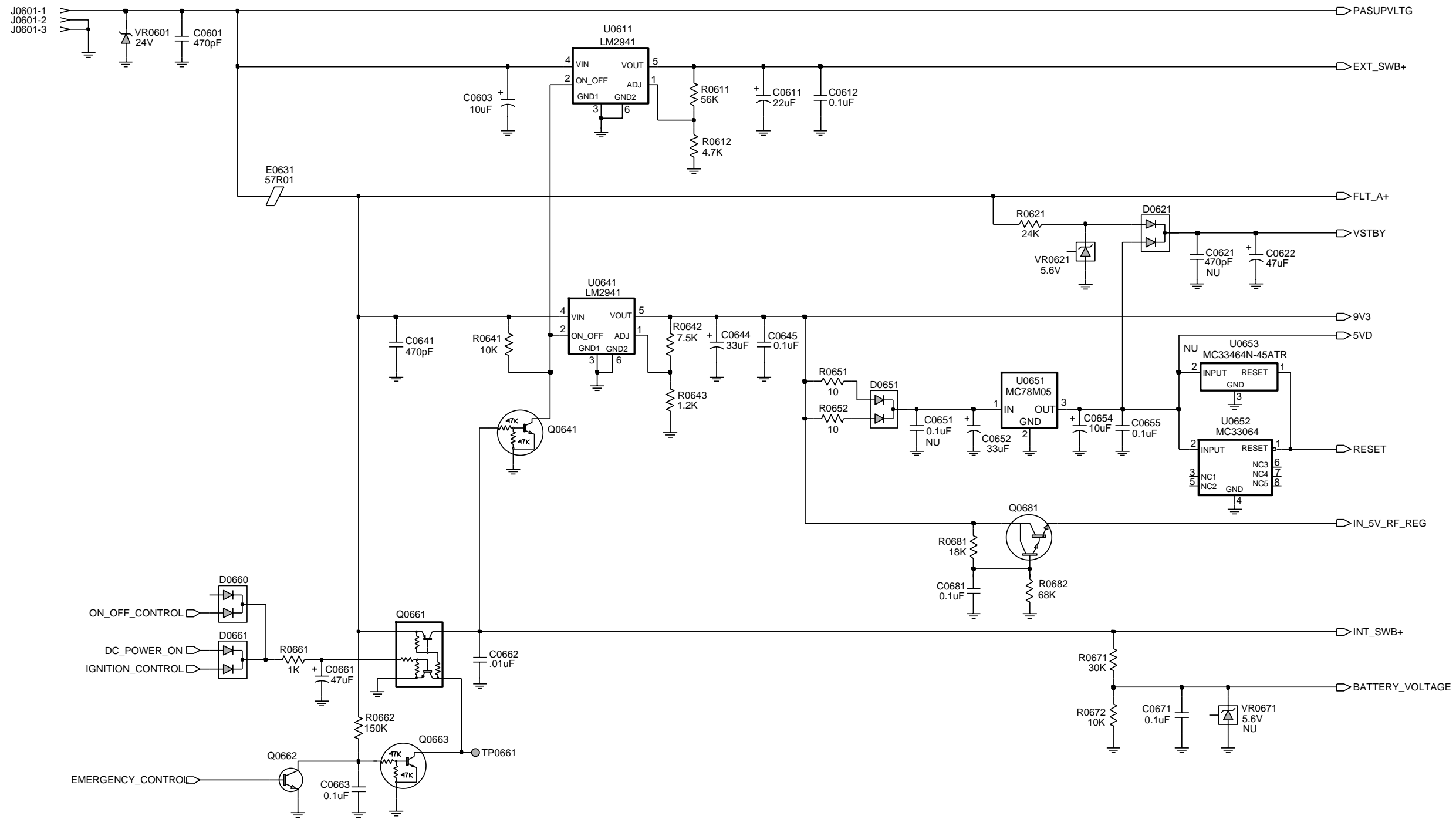

ZWG0130938-O

Controller T11 Schematic Diagram - Supply Voltage

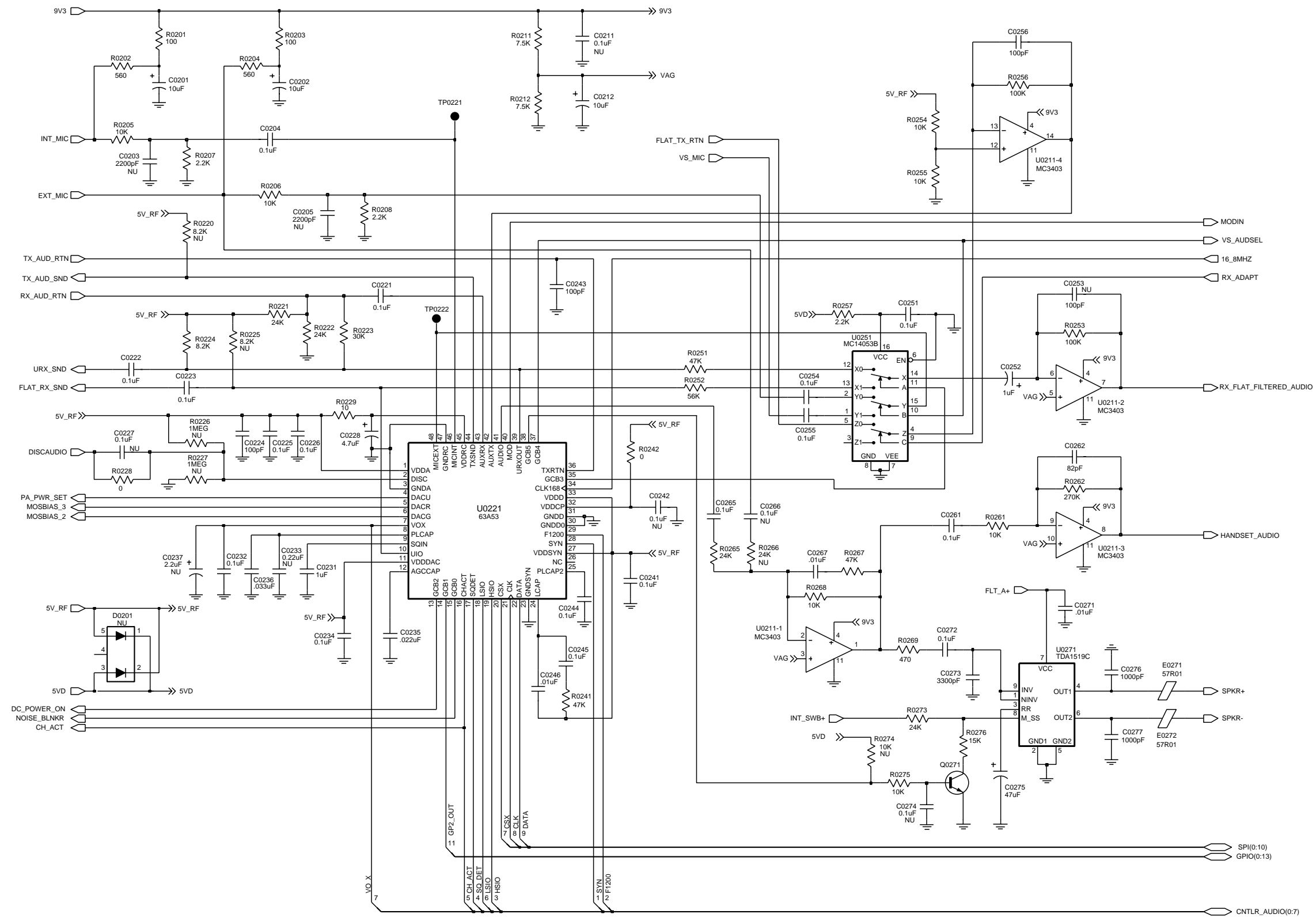

ZWG0130936-O

Controller T11

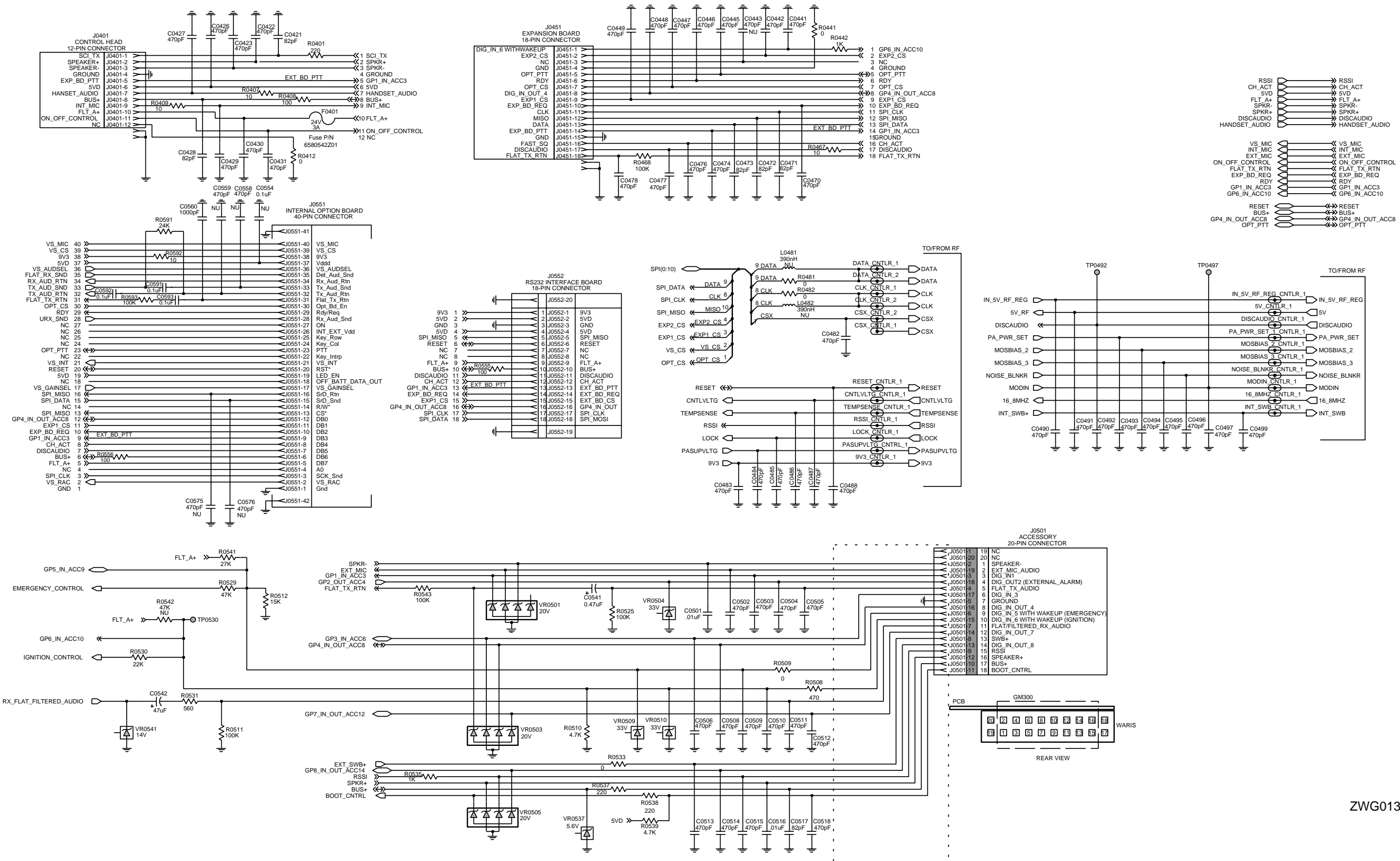

Controller T11 Schematic Diagram - I/O

ZWG0130937-O

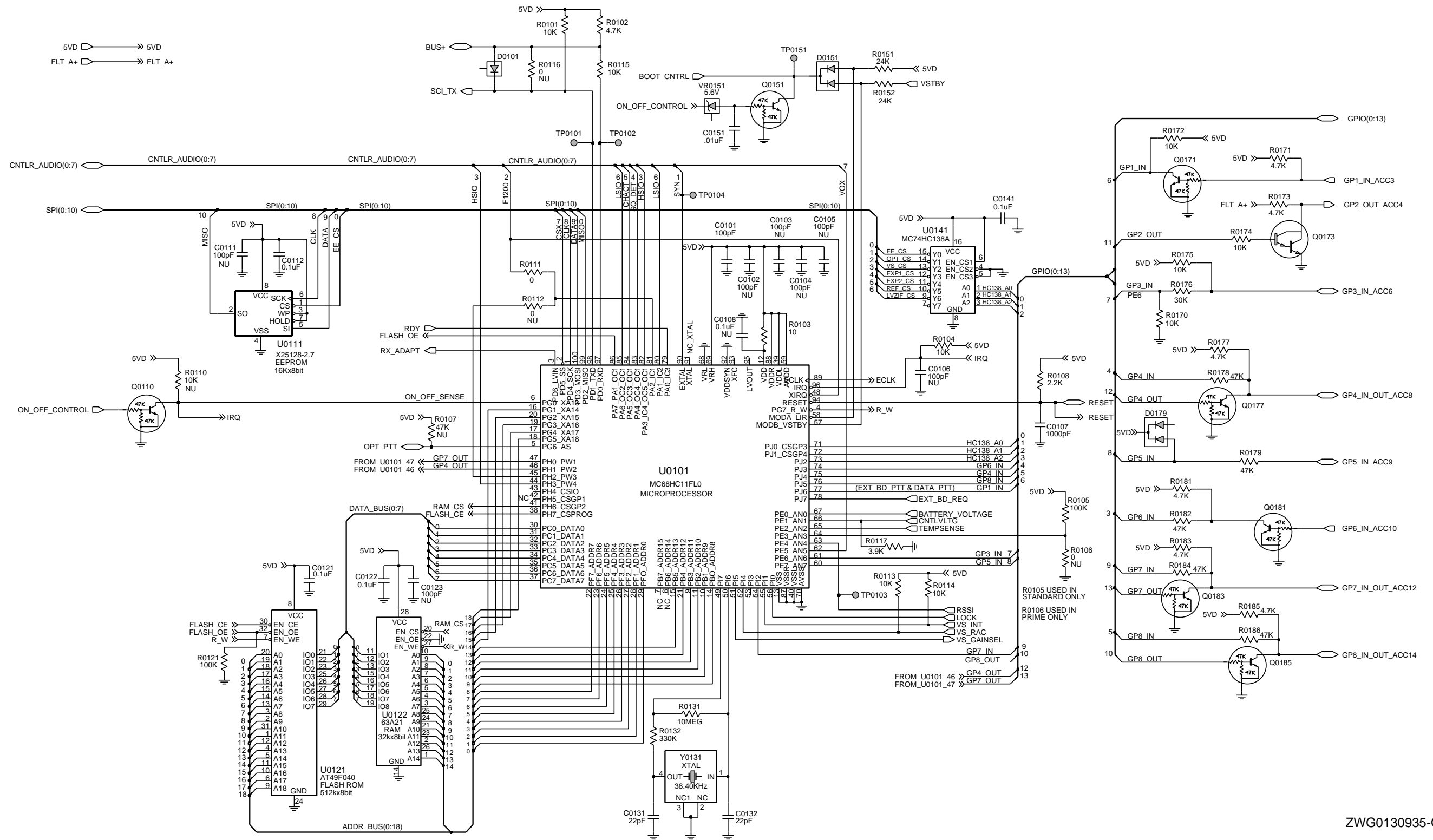

ZWG0130935-O

Controller T11 Schematic Diagram - Microprocessor

6.1 Controller T11 Parts List

Circuit Ref	Motorola Part No	Description
C0101	2113740F51	CAP, 100pF
C0107	2113741F25	CAP, 1000pF
C0112	2113743E20	CAP, 0.1uF
C0121	2113743E20	CAP, 0.1uF
C0122	2113743E20	CAP, 0.1uF
C0131	2113740F35	CAP, 22pF
C0132	2113740F35	CAP, 22pF
C0141	2113743E20	CAP, 0.1uF
C0151	2113741F49	CAP, .01uF
C0201	2311049A57	CAPP, 10uF
C0202	2311049A57	CAPP, 10uF
C0204	2113743E20	CAP, 0.1uF
C0212	2311049A57	CAPP, 10uF
C0221	2113743E20	CAP, 0.1uF
C0222	2113743E20	CAP, 0.1uF
C0223	2113743E20	CAP, 0.1uF
C0224	2113740F51	CAP, 100pF
C0225	2113743E20	CAP, 0.1uF
C0226	2113743E20	CAP, 0.1uF
C0228	2311049A56	CAPP, 4.7uF
C0231	2113743B29	CAP, 1uF
C0232	2113743E20	CAP, 0.1uF
C0234	2113743E20	CAP, 0.1uF
C0235	2113743E07	CAP, .022uF
C0236	2113743E10	CAP, .033uF
C0241	2113743E20	CAP, 0.1uF
C0243	2113740F51	CAP, 100pF
C0244	2113743E20	CAP, 0.1uF
C0245	2113743E20	CAP, 0.1uF
C0246	2113741F49	CAP, .01uF
C0251	2113743E20	CAP, 0.1uF
C0252	2311049A07	CAPP, 1uF
C0254	2113743E20	CAP, 0.1uF
C0255	2113743E20	CAP, 0.1uF
C0256	2113740F51	CAP, 100pF
C0261	2113743E20	CAP, 0.1uF
C0262	2113740F49	CAP, 82pF
C0265	2113743E20	CAP, 0.1uF
C0267	2113741F49	CAP, .01uF
C0271	2113741F49	CAP, .01uF
C0272	2113743E20	CAP, 0.1uF
C0273	2113741F37	CAP, 3300pF
C0275	2311049A99	CAPP, 47uF
C0276	2113741F25	CAP, 1000pF
C0277	2113741F25	CAP, 1000pF
C0290	2311049C01	CAPP, 10uF

Circuit Ref	Motorola Part No	Description
C0291	2311049C01	CAPP, 10uF
C0292	2311049C01	CAPP, 10uF
C0293	2311049C01	CAPP, 10uF
C0421	2113743N48	CAP, 82pF
C0422	2113741F17	CAP, 470pF
C0423	2113741F17	CAP, 470pF
C0426	2113743L09	CAP, 470pF
C0427	2113743L09	CAP, 470pF
C0428	2113743N48	CAP, 82pF
C0429	2113743L09	CAP, 470pF
C0430	2113741F17	CAP, 470pF
C0431	2113741F17	CAP, 470pF
C0441	2113743L09	CAP, 470pF
C0442	2113743L09	CAP, 470pF
C0445	2113743L09	CAP, 470pF
C0446	2113743L09	CAP, 470pF
C0447	2113743L09	CAP, 470pF
C0448	2113743L09	CAP, 470pF
C0449	2113743L09	CAP, 470pF
C0470	2113743L09	CAP, 470pF
C0471	2113743N48	CAP, 82pF
C0472	2113743N48	CAP, 82pF
C0473	2113743N48	CAP, 82pF
C0474	2113743L09	CAP, 470pF
C0476	2113743L09	CAP, 470pF
C0477	2113743L09	CAP, 470pF
C0478	2113743L09	CAP, 470pF
C0482	2113743L09	CAP, 470pF
C0483	2113743L09	CAP, 470pF
C0484	2113741F17	CAP, 470pF
C0485	2113743L09	CAP, 470pF
C0486	2113743L09	CAP, 470pF
C0487	2113743L09	CAP, 470pF
C0488	2113743L09	CAP, 470pF
C0490	2113743L09	CAP, 470pF
C0491	2113743L09	CAP, 470pF
C0492	2113743L09	CAP, 470pF
C0493	2113743L09	CAP, 470pF
C0494	2113743L09	CAP, 470pF
C0495	2113743L09	CAP, 470pF
C0496	2113743L09	CAP, 470pF
C0497	2113743L09	CAP, 470pF
C0499	2113743L09	CAP, 470pF
C0501	2113741F49	CAP, .01uF
C0502	2113741F17	CAP, 470pF
C0503	2113741F17	CAP, 470pF
C0504	2113741F17	CAP, 470pF

Circuit Ref	Motorola Part No	Description
C0505	2113741F17	CAP, 470pF
C0506	2113741F17	CAP, 470pF
C0508	2113741F17	CAP, 470pF
C0509	2113741F17	CAP, 470pF
C0510	2113741F17	CAP, 470pF
C0511	2113741F17	CAP, 470pF
C0512	2113741F17	CAP, 470pF
C0513	2113741F17	CAP, 470pF
C0514	2113741F17	CAP, 470pF
C0515	2113741F17	CAP, 470pF
C0516	2113741F49	CAP, .01uF
C0517	2113743N48	CAP, 82pF
C0518	2113741F17	CAP, 470pF
C0541	2311049A05	CAPP, 0.47uF
C0542	2311049A99	CAPP, 47uF
C0560	2113741F25	CAP, 1000pF
C0591	2113743E20	CAP, 0.1uF
C0592	2113743E20	CAP, 0.1uF
C0593	2113741B69	CAP, 0.1uF
C0601	2113741F17	CAP, 470pF
C0603	2380090M24	CAPP, 10uF
C0611	2311049C06	CAPP, 22uF
C0612	2113743E20	CAP, 0.1uF
C0622	2311049A99	CAPP, 47uF
C0641	2113741F17	CAP, 470pF
C0644	2311049A97	CAPP, 33uF
C0645	2113743E20	CAP, 0.1uF
C0652	2311049A97	CAPP, 33uF
C0654	2311049A57	CAPP, 10uF
C0655	2113743E20	CAP, 0.1uF
C0661	2311049C05	CAPP, 47uF
C0662	2113741F49	CAP, .01uF
C0663	2113743E20	CAP, 0.1uF
C0671	2113743E20	CAP, 0.1uF
C0681	2113743E20	CAP, 0.1uF
D0101	4813825A05	MMBD301
D0151	4813833C02	MMBD6100
D0179	4813833C02	MMBD6100
D0621	4813833C02	MMBD6100
D0651	4813833C02	MMBD6100
D0660	4813833C02	MMBD6100
D0661	4813833C02	MMBD6100
E0271	2484657R01	FERRITE BEAD
E0272	2484657R01	FERRITE BEAD
E0631	2484657R01	FERRITE BEAD
F0401	6580542Z01	FUSE

Circuit Ref	Motorola Part No	Description
J0401	0902636Y02	CONN, 12-PIN, CONTROL HEAD
J0451	0902636Y01	CONN, 18-PIN, EXPANSION BOARD
J0501	0986105B01	CONN, 20-PIN, ACCESSORY
J0551	0905505Y04	CONN, 40-PIN, INTERNAL OPTION
J0552	0905505Y03	CONN, 18-PIN, RS232
J0601	0986165B01	DC POWER CONNECTOR
Q0110	4880048M01	DTC144EKA
Q0151	4880048M01	DTC144EKA
Q0171	4880048M01	DTC144EKA
Q0173	4880052M01	RXT-A28
Q0177	4880048M01	DTC144EKA
Q0181	4880048M01	DTC144EKA
Q0183	4880048M01	DTC144EKA
Q0185	4880048M01	DTC144EKA
Q0271	4880214G02	MMBT3904
Q0641	4880048M01	DTC144EKA
Q0661	4805921T02	FMC2A
Q0662	4880214G02	MMBT3904
Q0663	4880048M01	DTC144EKA
Q0681	4880052M01	RXT-A28
R0101	0662057A73	RES, 10K
R0102	0662057A65	RES, 4.7K
R0103	0662057A01	RES, 10
R0104	0662057A73	RES, 10K
R0105	0662057A97	RES, 100K
R0108	0662057A57	RES, 2.2K
R0111	0662057B47	RES, 0
R0113	0662057A73	RES, 10K
R0114	0662057A73	RES, 10K
R0115	0662057A73	RES, 10K
R0117	0662057A63	RES, 3.9K
R0121	0662057A97	RES, 100K
R0131	0662057B46	RES, 10MEG
R0132	0662057B10	RES, 330K
R0151	0662057A82	RES, 24K
R0152	0662057A82	RES, 24K
R0170	0662057A73	RES, 10K
R0171	0662057A65	RES, 4.7K
R0172	0662057A73	RES, 10K
R0173	0662057A65	RES, 4.7K
R0174	0662057A73	RES, 10K
R0175	0662057A73	RES, 10K
R0176	0662057A84	RES, 30K

Circuit Ref	Motorola Part No	Description
R0177	0662057A65	RES, 4.7K
R0178	0662057A89	RES, 47K
R0179	0662057A89	RES, 47K
R0181	0662057A65	RES, 4.7K
R0182	0662057A89	RES, 47K
R0183	0662057A65	RES, 4.7K
R0184	0662057A89	RES, 47K
R0185	0662057A65	RES, 4.7K
R0186	0662057A89	RES, 47K
R0201	0662057A25	RES, 100
R0202	0662057A43	RES, 560
R0203	0662057A25	RES, 100
R0204	0662057A43	RES, 560
R0205	0662057A73	RES, 10K
R0206	0662057A73	RES, 10K
R0207	0662057A57	RES, 2.2K
R0208	0662057A57	RES, 2.2K
R0211	0660076E70	RES, 7.5K
R0212	0660076E70	RES, 7.5K
R0221	0662057A82	RES, 24K
R0222	0662057A82	RES, 24K
R0223	0662057A84	RES, 30K
R0224	0662057A71	RES, 8.2K
R0228	0662057B47	RES, 0
R0229	0662057A01	RES, 10
R0241	0662057A89	RES, 47K
R0242	0662057B47	RES, 0
R0251	0662057A89	RES, 47K
R0252	0662057A91	RES, 56K
R0253	0662057A97	RES, 100K
R0254	0662057A73	RES, 10K
R0255	0662057A73	RES, 10K
R0256	0662057A97	RES, 100K
R0257	0662057A57	RES, 2.2K
R0261	0662057A73	RES, 10K
R0262	0662057B08	RES, 270K
R0265	0662057A82	RES, 24K
R0267	0662057A89	RES, 47K
R0268	0662057A73	RES, 10K
R0269	0662057A41	RES, 470
R0273	0662057A82	RES, 24K
R0275	0662057A73	RES, 10K
R0276	0662057A77	RES, 15K
R0401	0662057A33	RES, 220
R0407	0662057M26	RES, 10
R0408	0662057A25	RES, 100
R0409	0662057M26	RES, 10

Circuit Ref	Motorola Part No	Description
R0412	0662057B47	RES, 0
R0441	0662057B47	RES, 0
R0442	0662057A49	RES, 1K
R0467	0662057M26	RES, 10
R0468	0662057A97	RES, 100K
R0481	0662057B47	RES, 0
R0482	0662057B47	RES, 0
R0508	0662057A41	RES, 470
R0509	0662057B47	RES, 0
R0510	0662057A65	RES, 4.7K
R0511	0662057A97	RES, 100K
R0512	0662057A77	RES, 15K
R0525	0662057A97	RES, 100K
R0529	0662057A89	RES, 47K
R0530	0662057A81	RES, 22K
R0531	0662057A43	RES, 560
R0533	0662057B47	RES, 0
R0535	0662057A49	RES, 1K
R0537	0662057A33	RES, 220
R0538	0662057A33	RES, 220
R0539	0662057A65	RES, 4.7K
R0541	0662057A83	RES, 27K
R0543	0662057A97	RES, 100K
R0555	0662057A25	RES, 100
R0556	0662057A25	RES, 100
R0591	0662057A82	RES, 24K
R0592	0662057A01	RES, 10
R0593	0662057A97	RES, 100K
R0611	0662057A91	RES, 56K
R0612	0662057A65	RES, 4.7K
R0621	0662057A82	RES, 24K
R0641	0662057A73	RES, 10K
R0642	0660076E70	RES, 7.5K
R0643	0660076E51	RES, 1.2K
R0651	0662057A01	RES, 10
R0652	0662057A01	RES, 10
R0661	0662057A49	RES, 1K
R0662	0662057B02	RES, 150K
R0671	0662057A84	RES, 30K
R0672	0662057A73	RES, 10K
R0681	0662057A79	RES, 18K
R0682	0662057A93	RES, 68K
U0101	5102226J56	MC68HC11FLO
U0111	5102463J64	EEPROM
U0121	5186137B01	FLASH ROM
U0122	5185748L01	SRAM
U0141	5113805A30	REMUX

Circuit Ref	Motorola Part No	Description
U0211	5183222M49	MC3403
U0221	5185130C53	ASFIC COMPANDER IC
U0251	5184704M60	MUX/DEMUX
U0271	5109699X01	AUDIO PA
U0611	5183308X01	LM2941
U0641	5183308X01	LM2941
U0651	5113816A07	MC78M05
U0652	5113815A02	MC33064
VR0151	4813830A15	MMBZ5232B
VR0501	4805656W09	MMQA20VT1
VR0503	4805656W09	MMQA20VT1
VR0504	4813830A40	MMBZ5257B
VR0505	4805656W09	MMQA20VT1
VR0509	4813830A40	MMBZ5257B
VR0510	4813830A40	MMBZ5257B
VR0537	4813830A15	MMBZ5232B
VR0541	4813830A27	MMBZ5244B
VR0601	4813832C77	TRANSIENT SUPPRESSOR
VR0621	4813830A15	MMBZ5232B
Y0131	4880113R19	CRYSTAL, 38.4 KHZ

* Motorola Depot Servicing only
 Reference designators with an asterisk indicate components which are not fieldreplaceable because they need to be calibrated with specialized factory equipment after installation. Radios in which these parts have been replaced in the field will be off frequency at temperature extremes.

7.0 Controller T12 / Schematic Diagrams

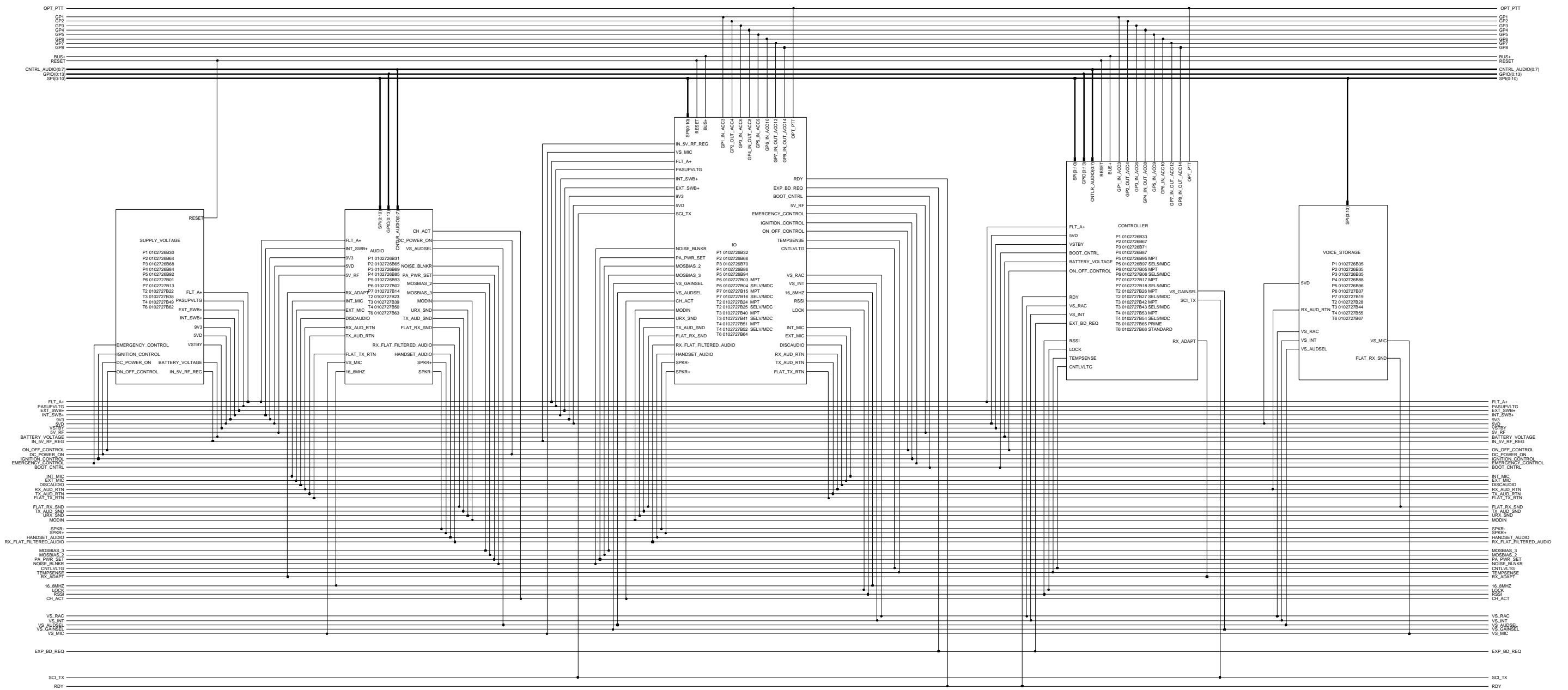

Controller Module Versions Changes						
	T4	T5	T6	T7	T8	T9
Supply Vltg	X	X			X	
Audio	X	X		X	X	
BD	X	X		X	X	X
CNTLR	X	X				X
Voice Stor						

ZWG0130934-O

Controller T12 Schematic Diagram - Overall

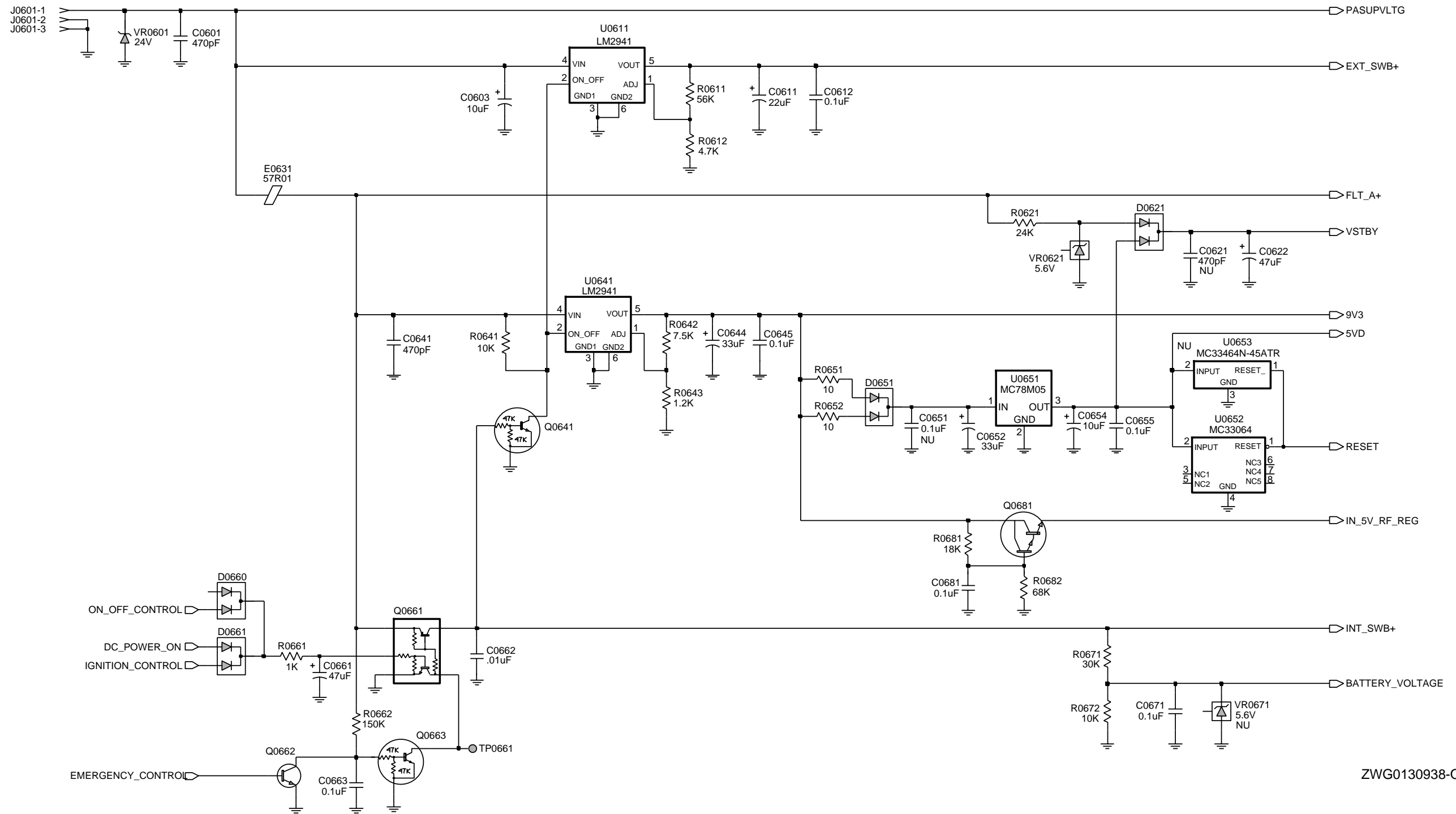

ZWG0130938-O

Controller T12 Schematic Diagram - Supply Voltage

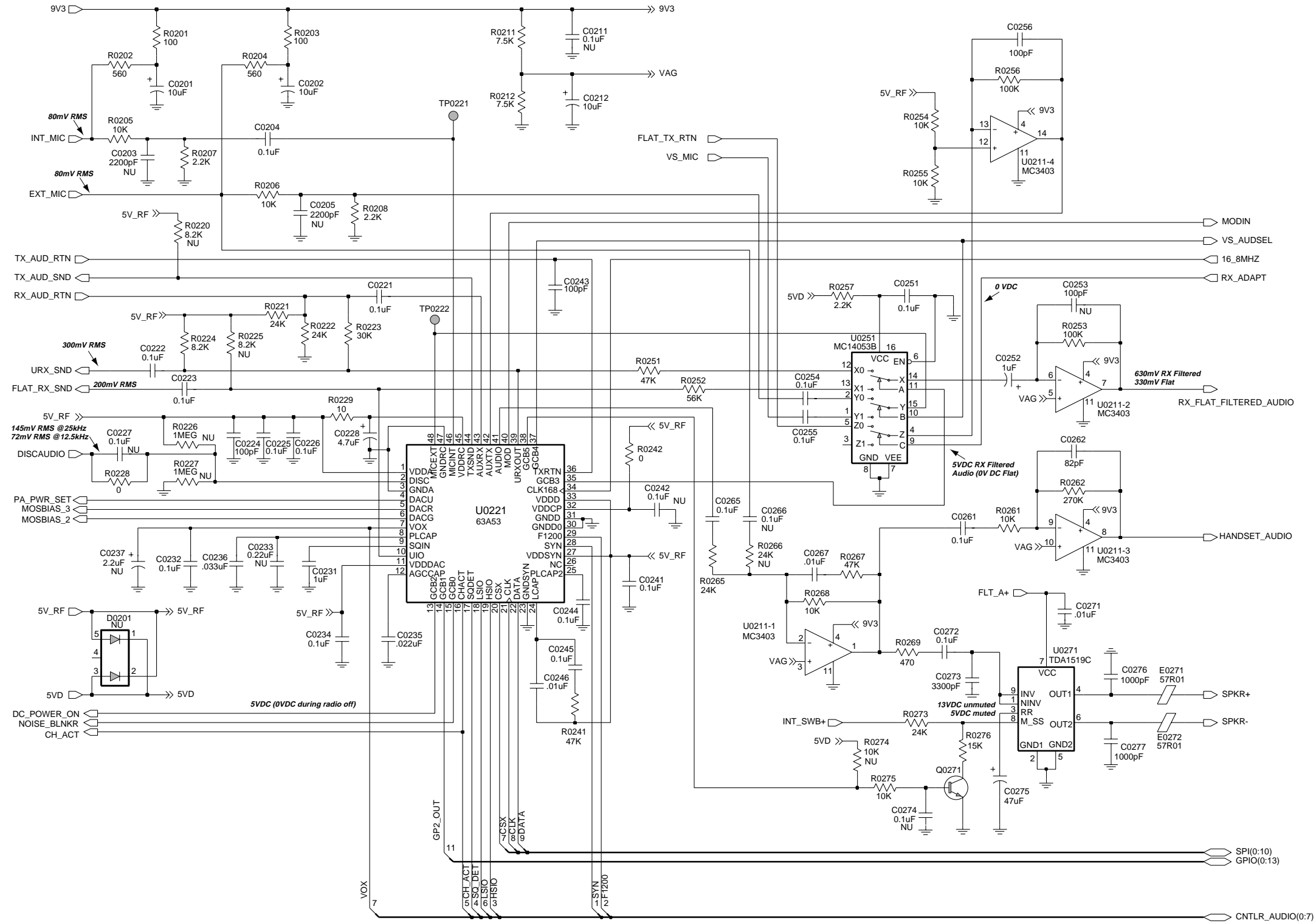

ZWG0131030-O

Controller T12 Schematic Diagram - Audio PA

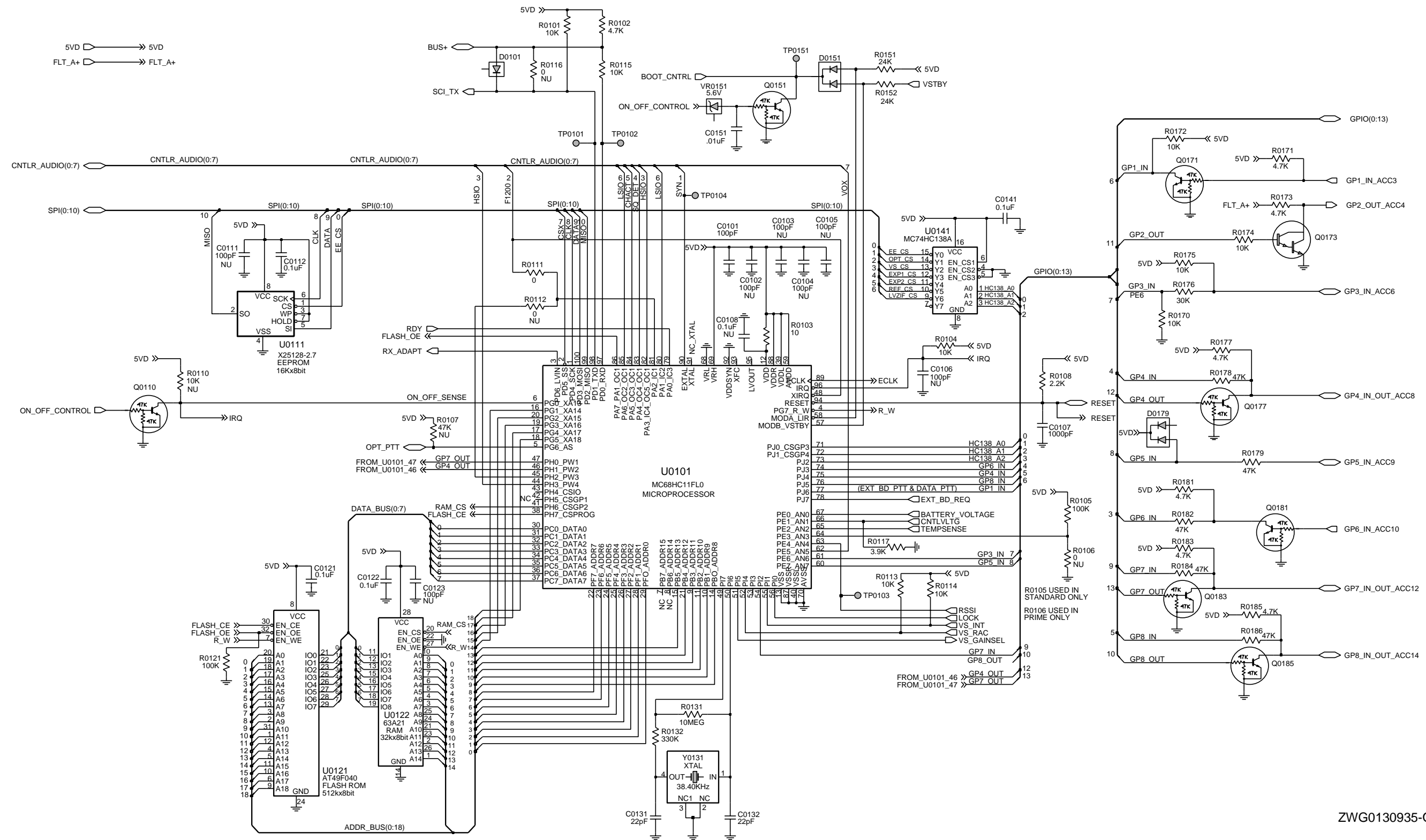

ZWG0130935-O

Controller T12 Schematic Diagram - Microprocessor

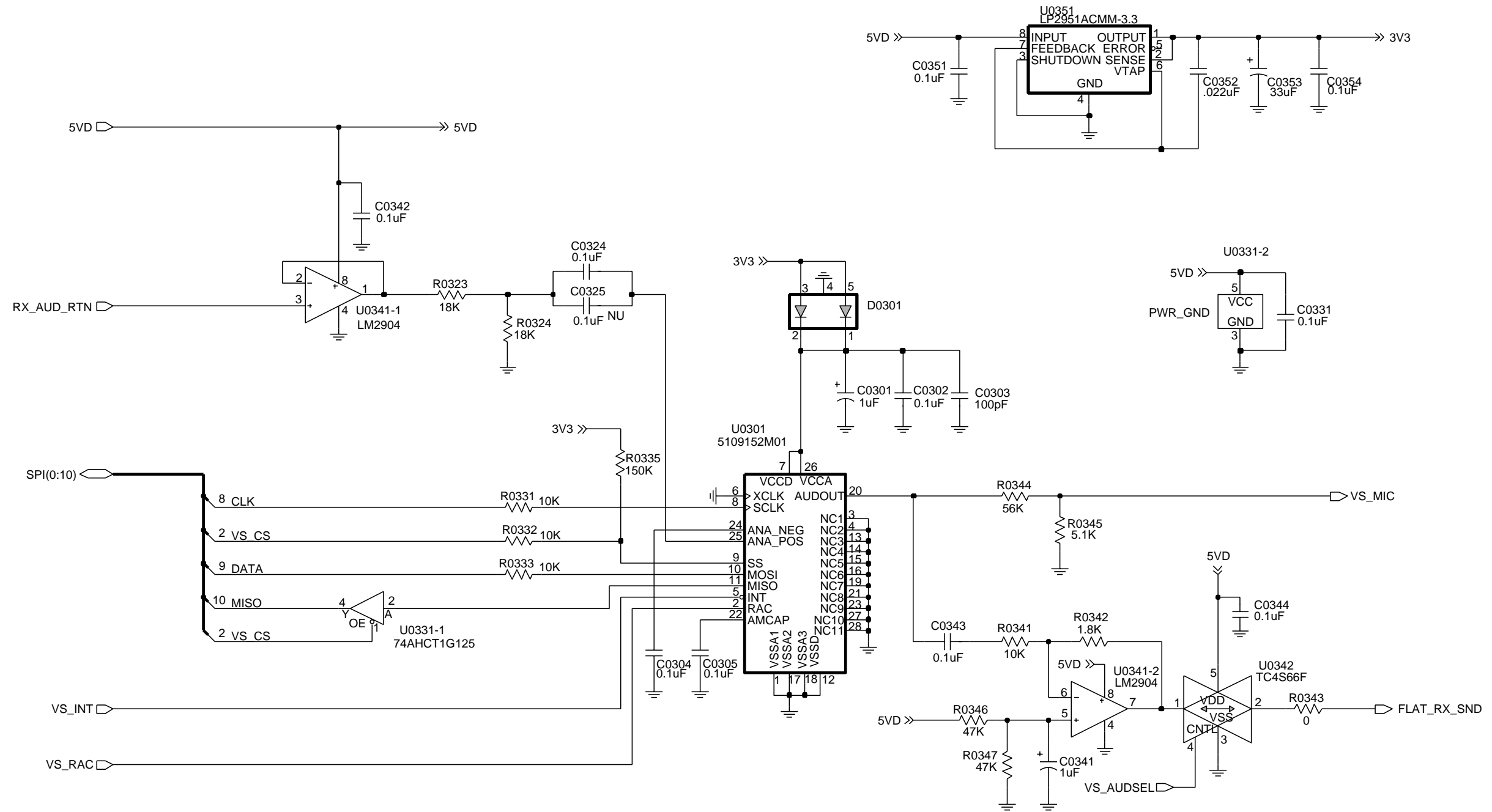

ZWG0130530-O

7.1 Controller T12 Parts List

Circuit Ref	Motorola Part No	Description
C0101	2113740F51	100pF 5% 50V
C0107	2113741F25	1nF 50V
C0112	2113743E20	100nF 16V
C0121	2113743E20	100nF 16V
C0122	2113743E20	100nF 16V
C0131	2113740F35	22pF 5% 50V
C0132	2113740F35	22pF 5% 50V
C0141	2113743E20	100nF 16V
C0151	2113741F49	10nF 50V
C0201	2311049A57	10uF 10% 16V
C0202	2311049A57	10uF 10% 16V
C0204	2113743E20	100nF 16V
C0212	2311049A57	10uF 10% 16V
C0221	2113743E20	100nF 16V
C0222	2113743E20	100nF 16V
C0223	2113743E20	100nF 16V
C0224	2113740F51	100pF 5% 50V
C0225	2113743E20	100nF 16V
C0226	2113743E20	100nF 16V
C0228	2311049A56	4.7uF 10% 16V
C0231	2113743B29	1 UF 10% 16V
C0232	2113743E20	100nF 16V
C0234	2113743E20	100nF 16V
C0235	2113743E07	22nF 16V
C0236	2113743E10	.033UF 10%
C0241	2113743E20	100nF 16V
C0243	2113740F51	100pF 5% 50V
C0244	2113743E20	100nF 16V
C0245	2113743E20	100nF 16V
C0246	2113741F49	10nF 50V
C0251	2113743E20	100nF 16V
C0252	2311049A07	1uF 10% 16V
C0254	2113743E20	100nF 16V
C0255	2113743E20	100nF 16V
C0256	2113740F51	100pF 5% 50V
C0261	2113743E20	100nF 16V
C0262	2113740F49	82pF 5% 50V NPO
C0265	2113743E20	100nF 16V
C0267	2113741F49	10nF 50V
C0271	2113741F49	10nF 50V
C0272	2113743E20	100nF 16V
C0273	2113741F37	3.3nF 50V
C0275	2311049A99	47uF 20% 10V
C0276	2113741F25	1nF 50V X7R
C0277	2113741F25	1nF 50V X7R
C0290	2311049C01	10uF (only LowBand)
C0291	2311049C01	10uF (only LowBand)
C0292	2311049C01	10uF (only LowBand)
C0293	2311049C01	10uF (only LowBand)

Circuit Ref	Motorola Part No	Description
C0301	2311049A07	TANT CP 1uF 10% 16V
Used in	GM1280 only	
C0302	2113743E20	100nF 16V
Used in	GM1280 only	
C0303	2113740F51	100pF 5% 50V
Used in	GM1280 only	
C0304	2113743E20	100nF 16V
Used in	GM1280 only	
C0305	2113743E20	100nF 16V
Used in	GM1280 only	
C0324	2113743E20	100nF 16V
Used in	GM1280 only	
C0331	2113743E20	100nF 16V
Used in	GM1280 only	
C0341	2311049A07	TANT CP 1uF 10% 16V
Used in	GM1280 only	
C0342	2113743E20	100nF 16V
Used in	GM1280 only	
C0343	2113743E20	100nF 16V
Used in	GM1280 only	
C0344	2113743E20	100nF 16V
Used in	GM1280 only	
C0351	2113743E20	100nF 16V
Used in	GM1280 only	
C0352	2113743E07	22nF 16V
Used in	GM1280 only	
C0353	2311049A97	TANT CHIP 33 UF
Used in	GM1280 only	
C0354	2113743E20	100nF 16V
Used in	GM1280 only	
C0421	2113743N48	82.0 PF 5%
C0422	2113741F17	470pF 50V
C0423	2113741F17	470pF 50V
C0426	2113743L09	470 PF 10%
C0427	2113743L09	470 PF 10%
C0428	2113743N48	82.0 PF 5%
C0429	2113743L09	470 PF 10%
C0430	2113741F17	470pF 50V
C0431	2113741F17	470pF 50V
C0441	2113743L09	470 PF 10%
C0442	2113743L09	470 PF 10%
C0445	2113743L09	470 PF 10%
C0446	2113743L09	470 PF 10%
C0447	2113743L09	470 PF 10%
C0448	2113743L09	470 PF 10%
C0449	2113743L09	470 PF 10%
C0470	2113743L09	470 PF 10%
C0471	2113743N48	82.0 PF 5%
C0472	2113743N48	82.0 PF 5%
C0473	2113743N48	82.0 PF 5%
C0474	2113743L09	470 PF 10%
C0476	2113743L09	470 PF 10%
C0477	2113743L09	470 PF 10%

Circuit Ref	Motorola Part No	Description
C0478	2113743L09	470 PF 10%
C0482	2113743L09	470 PF 10%
C0483	2113743L09	470 PF 10%
C0484	2113741F17	470pF 50V
C0485	2113743L09	470 PF 10%
C0486	2113743L09	470 PF 10%
C0487	2113743L09	470 PF 10%
C0488	2113743L09	470 PF 10%
C0490	2113743L09	470 PF 10%
C0491	2113743L09	470 PF 10%
C0492	2113743L09	470 PF 10%
C0493	2113743L09	470 PF 10%
C0494	2113743L09	470 PF 10%
C0495	2113743L09	470 PF 10%
C0496	2113743L09	470 PF 10%
C0497	2113743L09	470 PF 10%
C0499	2113743L09	470 PF 10%
C0501	2113741F49	10nF 50V
C0502	2113741F17	470pF 50V
C0503	2113741F17	470pF 50V
C0504	2113741F17	470pF 50V
C0505	2113741F17	470pF 50V
C0506	2113741F17	470pF 50V
C0508	2113741F17	470pF 50V (
C0509	2113741F17	470pF 50V
C0510	2113741F17	470pF 50V
C0511	2113741F17	470pF 50V
C0512	2113741F17	470pF 50V
C0513	2113741F17	470pF 50V
C0514	2113741F17	470pF 50V
C0515	2113741F17	470pF 50V
C0516	2113741F49	10nF 50V
C0517	2113743N48	82.0 PF 5%
C0518	2113741F17	470pF 50V
C0541	2311049A05	470nF 10% 25V
C0542	2311049A99	47uF 20% 10V
C0560	2113743L17	1nF 10%
C0591	2113743E20	100nF 16V
C0592	2113743E20	100nF 16V
C0601	2113741F17	470pF 50V
C0603	2380090M24	LYT 10uF 50V 20%
C0611	2311049C06	CP 22uF 20% 35V
C0612	2113743E20	100nF 16V
C0622	2311049A99	CP 47uF 20%
C0641	2113741F17	470pF 50V
C0644	2311049A97	CHIP 33 UF
C0645	2113743E20	100nF 16VD
C0652	2311049A97	CHIP 33 UF 16
C0654	2311049A57	CP 10uF 10% 16V
C0655	2113743E20	100nF 16V

Circuit Ref	Motorola Part No	Description
C0661	2311049C05	CP 47uF 10% 16V
C0662	2113741F49	10nF 50V
C0663	2113743E20	100nF 16V
C0671	2113743E20	100nF 16V
C0681	2113743E20	100nF 16V
D0101	4813825A05	CHIP SCHOTTKY
D0151	4813833C02	DUAL SOT MMBD6100
D0179	4813833C02	DUAL SOT MMBD6100
D0301	4802245J47	SCHOTTKY BARRIER
Used in	GM1280 only	(RB471E)
D0621	4813833C02	DUAL SOT MMBD6100
D0651	4813833C02	DUAL SOT MMBD6100
D0660	4813833C02	DUAL SOT MMBD6100
D0661	4813833C02	DUAL SOT MMBD6100
E0271	2484657R01	Ferrite Bead
E0272	2484657R01	Ferrite Bead
E0631	2484657R01	Ferrite Bead
F0401	6580542Z01	3A 24V
J0401	0902636Y02	CONN FLEX 12 PIN
J0451	0902636Y01	CONN FLEX SIDE ENTRY
J0501	0986105B01	CONN SMD 20 PIN
J0551	0905505Y04	CONN ZIF HORIZONTAL
J0552	0905505Y03	CONN ZIF 18PIN
J0601	0986165B01	DC PWR CONN
Q0110	4880048M01	NPN DIG 47k/47k
Q0151	4880048M01	NPN DIG 47k/47k
Q0171	4880048M01	NPN DIG 47k/47k
Q0173	4880052M01	NPN DRLNGTN MXTA
Q0177	4880048M01	NPN DIG 47k/47k
Q0181	4880048M01	NPN DIG 47k/47k
Q0183	4880048M01	NPN DIG 47k/47k
Q0185	4880048M01	NPN DIG 47k/47k
Q0271	4880214G02	NPN 40V .2A
Q0641	4880048M01	NPN DIG 47k/47k
Q0661	4805921T02	DUAL ROHM FMC2 RH
Q0662	4880214G02	NPN 40V .2A
Q0663	4880048M01	NPN DIG 47k/47k
Q0681	4880052M01	NPN DRLNGTN MXTA
R0101	0662057A73	10k 1/16W 5%
R0102	0662057A65	4k7 1/16W 5%
R0103	0662057A01	10 1/16W 5%
R0104	0662057A73	10k 1/16W 5%
R0105	0662057A97	100k 1/16W
Used in	GM140/160	GM340/360/640/660 only
R0106	0662057B47	0 1/16W
Used in		GM380/GM1280 only
R0108	0662057A57	2k2 1/16W 5%
R0111	0662057B47	0 1/16W 0306
R0113	0662057A73	10k 1/16W 5%
R0114	0662057A73	10k 1/16W 5%
R0115	0662057A73	10k 1/16W 5%
R0117	0662057A63	3k9 1/16W 5%

Circuit Ref	Motorola Part No	Description
R0121	0662057A97	100k 1/16W
R0131	0662057B46	10.0 MEG OHMS 5%
R0132	0662057B10	330k 1/16W 5%
R0151	0662057A82	24K 1/16W 5%
R0152	0662057A82	24K 1/16W 5%
R0170	0662057A73	10k 1/16W 5%
R0171	0662057A65	4k7 1/16W 5%
R0172	0662057A73	10k 1/16W 5%
R0173	0662057A65	4k7 1/16W 5%
R0174	0662057A73	10k 1/16W 5%
R0175	0662057A73	10k 1/16W 5%
R0176	0662057A84	30k 1/16W 5%
R0177	0662057A65	4k7 1/16W 5%
R0178	0662057A89	47k 1/16W 5%
R0179	0662057A89	47k 1/16W 5%
R0181	0662057A65	4k7 1/16W 5%
R0182	0662057A89	47k 1/16W 5%
R0183	0662057A65	4k7 1/16W 5%
R0184	0662057A89	47k 1/16W 5%
R0185	0662057A65	4k7 1/16W 5%
R0186	0662057A89	47k 1/16W 5%
R0201	0662057A25	100 1/16W 5%
R0202	0662057A43	560 1/16W 5%
R0203	0662057A25	100 1/16W 5%
R0204	0662057A43	560 1/16W 5%
R0205	0662057A73	10k 1/16W 5%
R0206	0662057A73	10k 1/16W 5%
R0207	0662057A57	2k2 1/16W 5%
R0208	0662057A57	2k2 1/16W 5%
R0211	0660076E70	FILM 7500
R0212	0660076E70	FILM 7500
R0221	0662057A82	24K 1/16W 5%
R0222	0662057A82	24K 1/16W 5%
R0223	0662057A84	30k 1/16W 5%
R0224	0662057A71	8k2 1/16W 5%
R0228	0662057B47	0 1/16W
R0229	0662057A01	10 1/16W 5%
R0241	0662057A89	47k 1/16W 5%
R0242	0662057B47	0 1/16W
R0251	0662057A89	47k 1/16W 5%
R0252	0662057A91	56K 1/16W 5%
R0253	0662057A97	100k 1/16W
R0254	0662057A73	10k 1/16W 5%
R0255	0662057A73	10k 1/16W 5%
R0256	0662057A97	100k 1/16W
R0257	0662057A57	2k2 1/16W 5%
R0261	0662057A73	10k 1/16W 5%
R0262	0662057B08	270k 1/16W
R0265	0662057A82	24K 1/16W 5%
R0267	0662057A89	47k 1/16W 5%
R0268	0662057A73	10k 1/16W 5%

Circuit Ref	Motorola Part No	Description
R0269	0662057A41	470 1/16W 5%
R0273	0662057A82	24K 1/16W 5%
R0275	0662057A73	10k 1/16W 5%
R0276	0662057A77	15k 1/16W 5%
R0323	0662057A79	18k 1/16W 5%
Used in	GM1280 only	
R0324	0662057A79	18k 1/16W 5%
Used in	GM1280 only	
R0331	0662057A73	10k 1/16W 5%
Used in	GM1280 only	
R0332	0662057A73	10k 1/16W 5%
Used in	GM1280 only	
R0333	0662057A73	10k 1/16W 5%
Used in	GM1280 only	
R0335	0662057B02	150k 1/16W
Used in	GM1280 only	
R0341	0662057A73	10k 1/16W
Used in	GM1280 only	
R0342	0662057A55	1k8 1/16W
Used in	GM1280 only	
R0343	0662057B47	0 1/16W
Used in	GM1280 only	
R0344	0662057A91	56K 1/16W
Used in	GM1280 only	
R0345	0662057A66	5k1 1/16W
Used in	GM1280 only	
R0346	0662057A89	47k 1/16W
Used in	GM1280 only	
R0347	0662057A89	47k 1/16W
Used in	GM1280 only	
R0401	0662057A33	220 1/16W
R0407	0662057M26	10 5% 20X40
R0408	0662057A25	100 1/16W 5%
R0409	0662057M26	10 5% 20X40
R0412	0662057B47	0 1/16W
R0441	0662057B47	0 1/16W
R0442	0662057A49	1k 1/16W 5%
R0467	0662057M26	10 5% 20X40
R0468	0662057A97	100k 1/16W
R0481	0662057B47	0 1/16W
R0482	0662057B47	0 1/16W
R0508	0662057A41	470 1/16W 5%
R0509	0662057B47	0 1/16W
R0510	0662057A65	4k7 1/16W 5%
R0511	0662057A97	100k 1/16W
R0512	0662057A77	15k 1/16W 5%
R0525	0662057A97	100k 1/16W
R0529	0662057A89	47k 1/16W 5%
R0530	0662057A81	22k 1/16W 5%
R0531	0662057A43	560 1/16W 5%
R0533	0662057B47	0 1/16W
R0535	0662057A49	1k 1/16W 5%

Circuit Ref	Motorola Part No	Description
R0537	0662057A33	220 1/16W 5%
R0538	0662057A33	220 1/16W 5%
R0539	0662057A65	4k7 1/16W 5%
R0541	0662057A83	27k 1/16W 5%
R0543	0662057A97	100k 1/16W
R0555	0662057A25	100 1/16W 5%
R0556	0662057A25	100 1/16W 5%
R0591	0662057A82	24K 1/16W 5%
R0592	0662057A01	10 1/16W 5%
R0593	0662057A97	100k 1/16W
R0611	0662057A91	56K 1/16W
R0612	0662057A65	4k7 1/16W
R0621	0662057A82	24K 1/16W
R0641	0662057A73	10k 1/16W
R0642	0660076E70	FILM 7500
R0643	0660076E51	FILM 1200
R0651	0662057A01	10 1/16W 5%
R0652	0662057A01	10 1/16W 5%
R0661	0662057A49	1k 1/16W 5%
R0662	0662057B02	150k 1/16W
R0671	0662057A84	30k 1/16W 5%
R0672	0662057A73	10k 1/16W 5%
R0681	0662057A79	18k 1/16W 5%
R0682	0662057A93	68k 1/16W 5%
U0101	5102226J56	MICRO PROCESSOR MC68HC1 1FLO
* U0111	5102463J64	EEPROM X25128-2.7 SO8
* U0121	5186137B01	512KX8 FLASH ROM (AT49BV020)
U0122	5185748L01	32K x 8 SRAM
U0141	5113805A30	10F8 DCDR/REMUX 74HC138
U0211	5183222M49	QUAD OPAMP __3403
U0221	5185130C53	ASFICCMP 0.5MM TQFP
U0251	5184704M60	MUX/DEMUX,TRIPLE 2-
U0271	5109699X01	AUDIO PA TDA1519C
U0301	5109152M01	EEPROM ANALOG
Used in	GM1280 only	ISD33120EI
U0331	5186204B01	BUFFER/DRIVER
Used in	GM1280 only	74AHCT1G125
U0341	5180932W01	LINEAR IC OP AMP
Used in	GM1280 only	
U0342	5105750U28	SNGL ANALOG SWITCH
Used in	GM1280 only	SMD
U0351	5102463J40	REGULATOR, 3.3V,
Used in	GM1280 only	LP2951CM-3.3
U0611	5183308X01	ADJ VLTG REG LM2941 TO263
U0641	5183308X01	ADJ VLTG REG LM2941 TO263
U0651	5113816A07	REG 5V POS 500MA MC78M05

Circuit Ref	Motorola Part No	Description
U0652	5113815A02	MC33064
VR0151	4813830A15	5.6V 5% 225mW
VR0501	4805656W09	ZENER QUAD MMQA20VT1
VR0503	4805656W09	ZENER QUAD MMQA20VT1
VR0504	4813830A40	SOC23 AUTO SDN
VR0505	4805656W09	ZENER QUAD MMQA20VT1
VR0509	4813830A40	SOC23 AUTO SDN
VR0510	4813830A40	SOC23 AUTO SDN
VR0537	4813830A15	5.6V 5% 225mW
VR0541	4813830A27	14V 5% 225MW
VR0601	4813832C77	TRANS SUP. 24V HIGH POWER
VR0621	4813830A15	5.6V 5% 225mW
Y0131	4880113R19	CRYSTAL 38.4KHz

* Motorola Depot Servicing only
 Reference designators with an asterisk indicate components which are not fieldreplaceable because they need to be calibrated with specialized factory equipment after installation. Radios in which these parts have been replaced in the field will be off frequency at temperature extremes.

